



ALUMINUM ACCESSORIES

Aluminum foot plate 6 series



H3060FP12

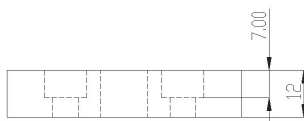
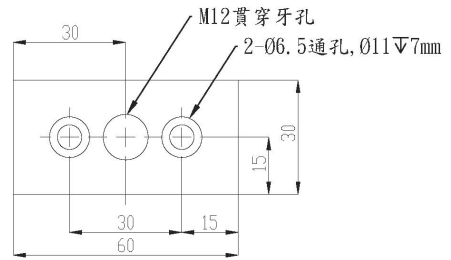

H3060FP16

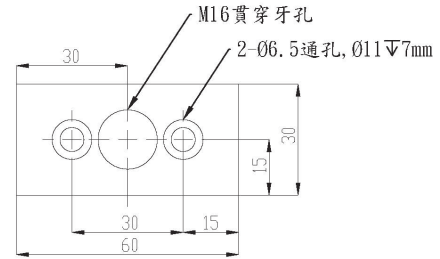

Unit: mm

Item No.	Material	Surface finishing	Color	Application	Load capacity(Kg)
H3060FP12	Aluminum die casting	Powder Coating	Silver	Used with M12 leveling feet and industrial casters	300
H3060FP16				Used with M16 leveling feet and industrial casters	1000



H6060FP12

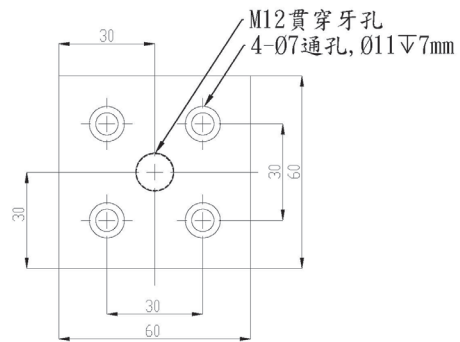

H6060FP16

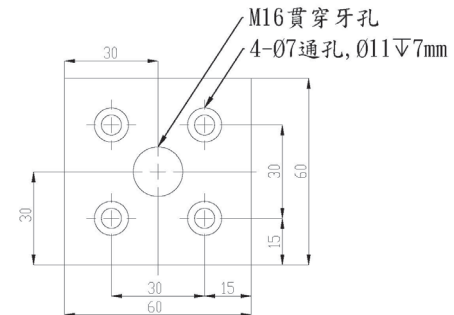

Unit: mm

Item No.	Material	Surface finishing	Color	Application	Load capacity(Kg)
H6060FP12	Aluminum die casting	Powder Coating	Silver	Used with M12 leveling feet and industrial casters	300
H6060FP16				Used with M16 leveling feet and industrial casters	1000

Aluminum foot plate 6 series



H6060FPR12

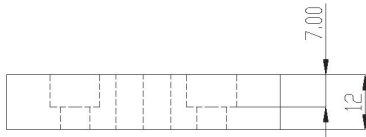
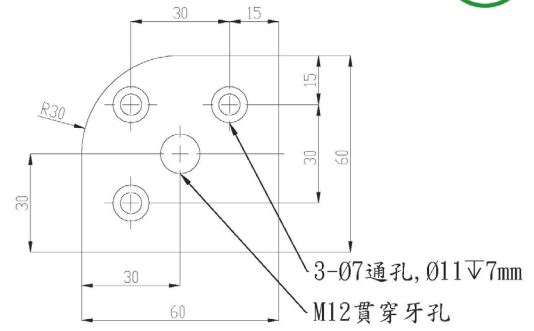

H6060FPR16

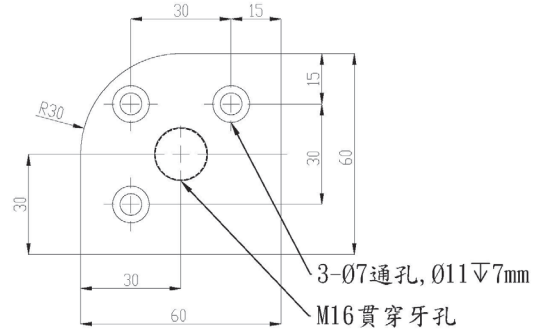

Unit: mm

Item No.	Material	Surface finishing	Color	Application	Load capacity(Kg)
H6060FPR12	Aluminum die casting	Powder Coating	Silver	Used with M12 leveling feet and industrial casters	300
H6060FPR16				Used with M16 leveling feet and industrial casters	1000

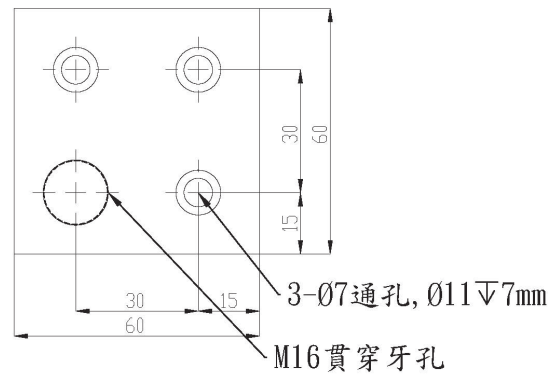

Unit: mm

Item No.	Material	Surface finishing	Color	Application	Load capacity(Kg)
H6060FPN16	Aluminum die casting	Powder Coating	Silver	Used with M16 leveling feet and industrial casters	1000

Aluminum foot plate 6 series



H06190FB

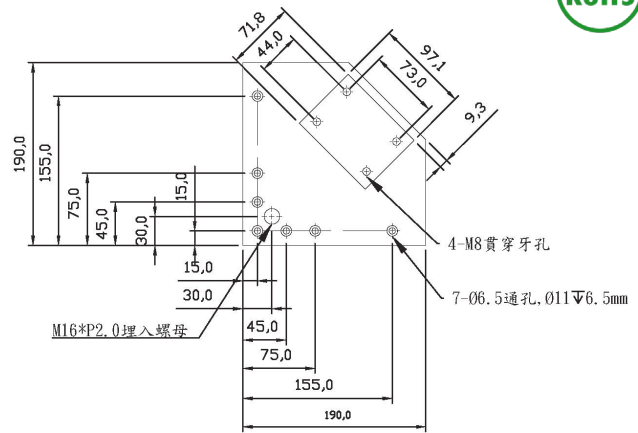

H06190FBR

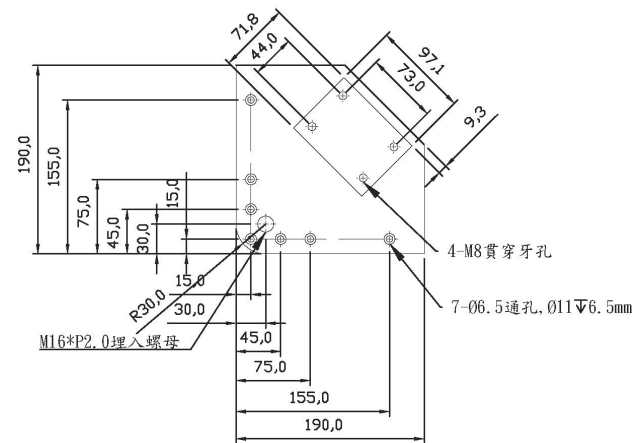
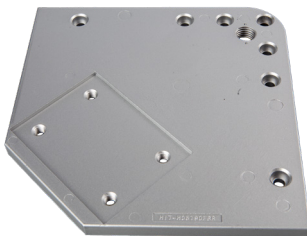

H06190FBN

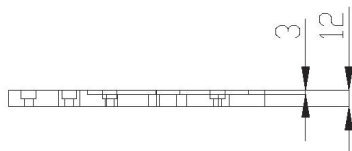
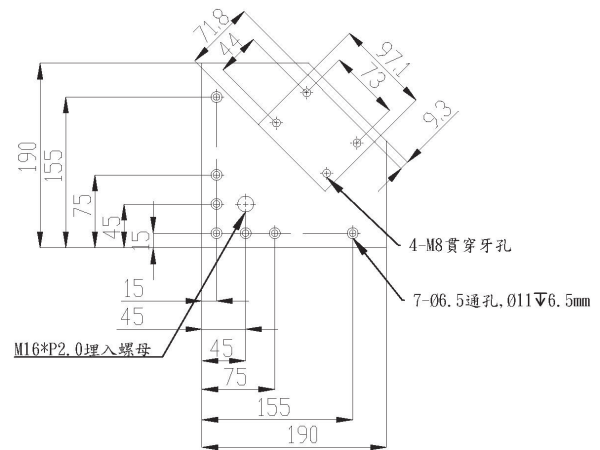
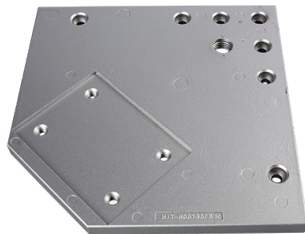

Unit: mm

Item No.	Material	Surface finishing	Color	Application	Load capacity(Kg)
H06190FB	Aluminum die casting	Powder Coating	Silver	Used with M16 leveling feet and industrial casters	1000
H06190FBR					
H06190FBN					

Aluminum foot plate 8 series



H4080FP12

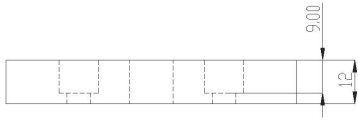
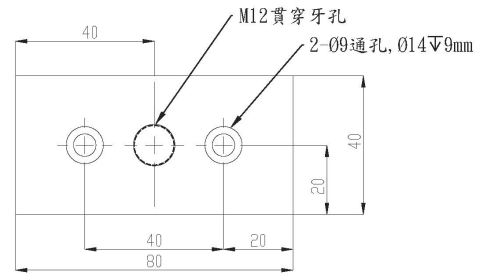

H4080FP16

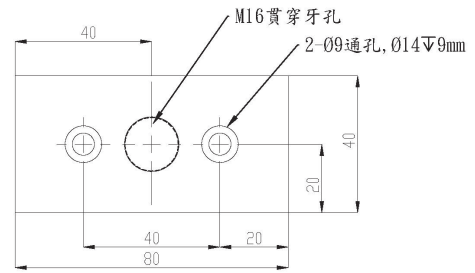

Unit: mm

Item No.	Material	Surface finishing	Color	Application	Load capacity(Kg)
H4080FP12	Aluminum die casting	Powder Coating	Silver	Used with M12 leveling feet and industrial casters	300
H4080FP16				Used with M16 leveling feet and industrial casters	1000



H8080FP12

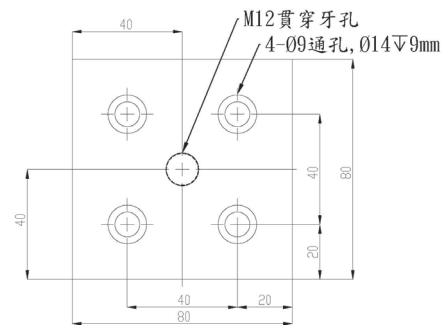

H8080FP16

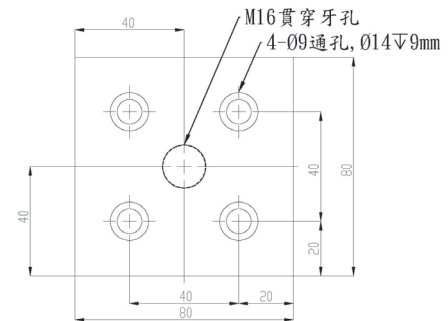

Unit: mm

Item No.	Material	Surface finishing	Color	Application	Load capacity(Kg)
H8080FP12	Aluminum die casting	Powder Coating	Silver	Used with M12 leveling feet and industrial casters	1000
H8080FP16				Used with M16 leveling feet and industrial casters	

Aluminum foot plate 8 series



H8080FPR12

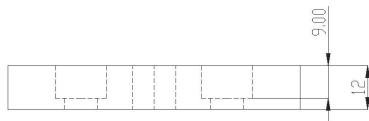
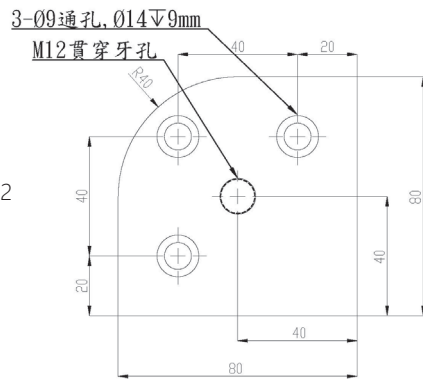

H8080FPR16

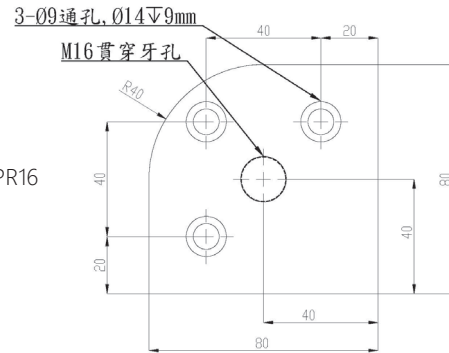

Unit: mm

Item No.	Material	Surface finishing	Color	Application	Load capacity(Kg)
H8080FPR12	Aluminum die casting	Powder Coating	Silver	Used with M12 leveling feet and industrial casters	1000
H8080FPR16				Used with M16 leveling feet and industrial casters	

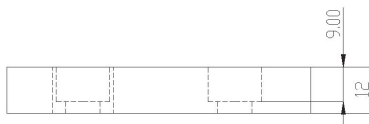
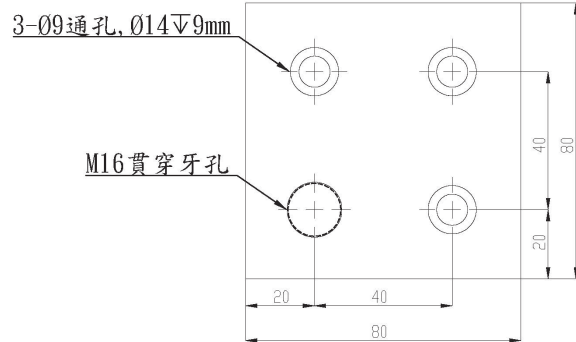

Unit: mm

Item No.	Material	Surface finishing	Color	Application	Load capacity(Kg)
H8080FPN16	Aluminum die casting	Powder Coating	Silver	Used with M16 leveling feet and industrial casters	1000

Aluminum foot plate 8 series



H08210FB

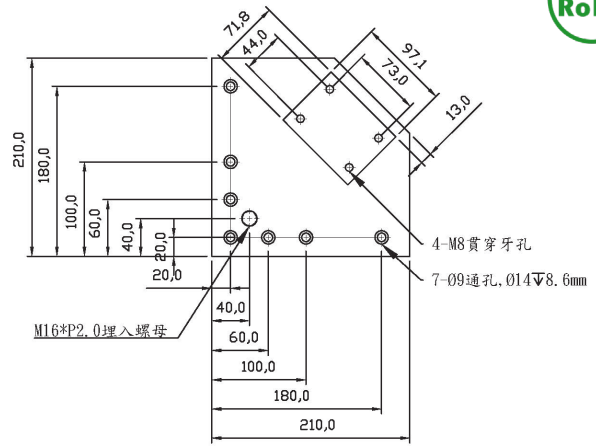

H08210FBR

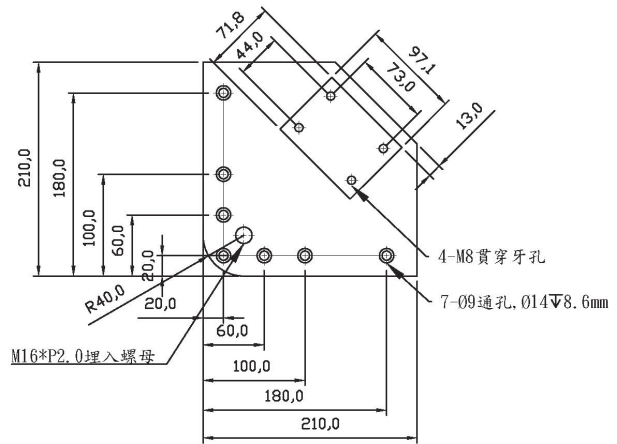
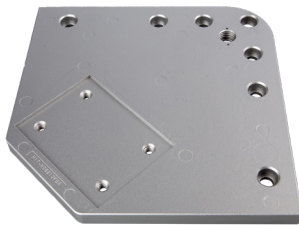

H08210FBN

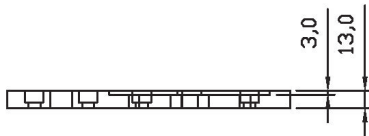
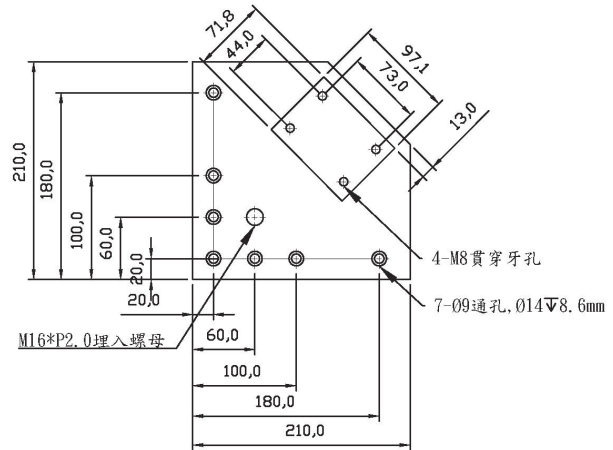

Unit: mm

Item No.	Material	Surface finishing	Color	Application	Load capacity(Kg)
H08210FB	Aluminum die casting	Powder Coating	Silver	Used with M16 leveling feet and industrial casters	1000
H08210FBR					
H08210FBN					

Aluminum foot plate 8 series



H0880230FBNR

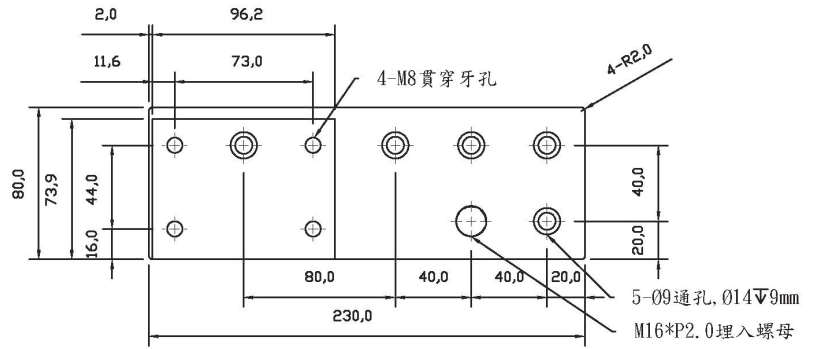

H0880230FBNL

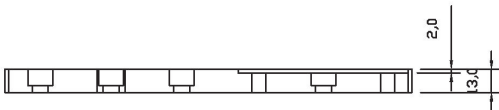
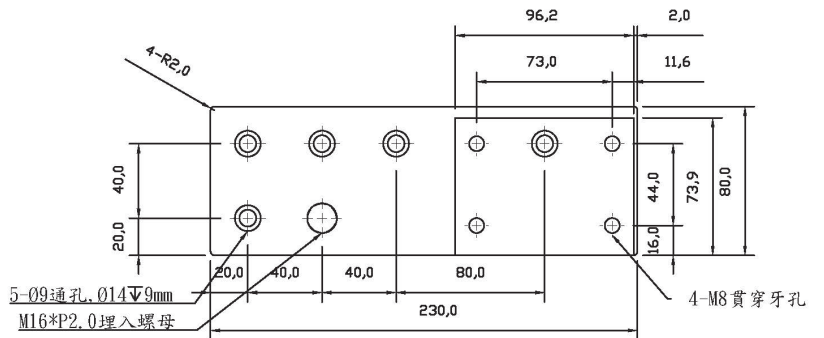

Unit: mm

Item No.	Material	Surface finishing	Color	Application	Load capacity(Kg)
H0880230FBNR	Aluminum die casting	Powder Coating	Silver	Used with M16 leveling feet and industrial casters	1000
H0880230FBNL					

Triangular connection block 2 series/ 6 series

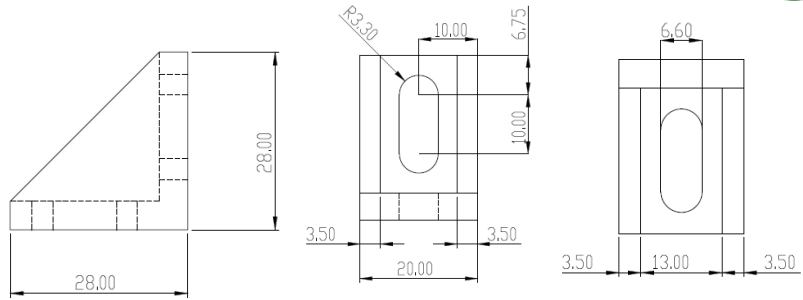

Unit: mm

Item No.	Material	Surface finishing	Color	Application
HCN2020	Aluminum die casting	Powder Coating	Silver	2 series connect aluminum accessories
HCN2020B		ED Coating	Black	

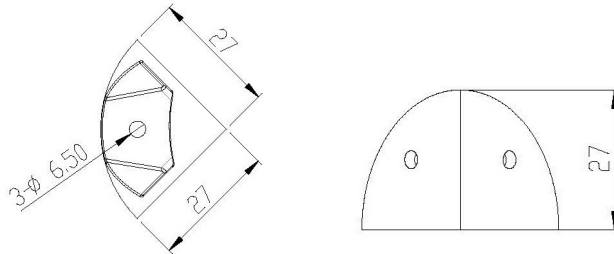

Unit: mm

Item No.	Double pin joint	No pin joint	Material	Surface finishing	Color	Application
HCN30R		V	Aluminum die casting	Powder Coating	Silver	6 series connect aluminum accessories

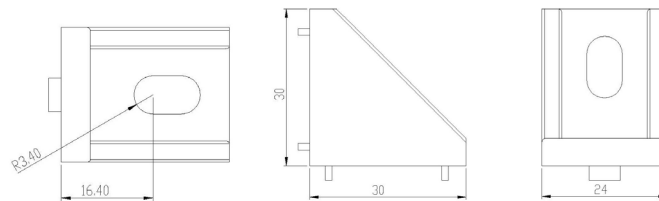

Unit: mm

Item No.	Double pin joint	No pin joint	Material	Surface finishing	Color	Application
HCN2430	V		Aluminum die casting	Powder Coating	Silver	6 series connect aluminum accessories
HCN2430K		V				
HCN2430B	V			ED Coating	Black	
HCN2430KB		V				

Triangular connection block 6 series

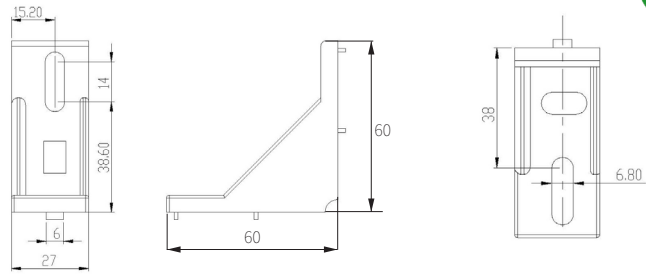

Unit: mm

Item No.	Double pin joint	No pin joint	Material	Surface finishing	Color	Application
HCN2760	V		Aluminum die casting	Powder Coating	Silver	6 series connect aluminum accessories
HCN2760K		V				
HCN2760B	V			ED Coating	Black	
HCN2760KB		V				

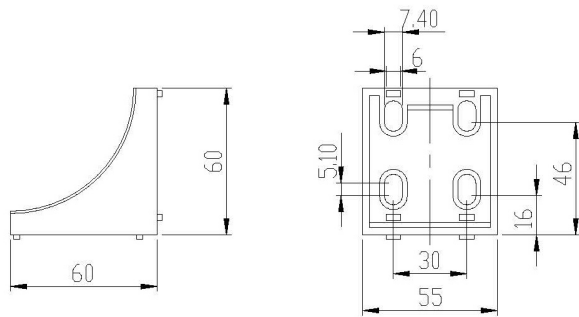

Unit: mm

Item No.	Double pin joint	No pin joint	Material	Surface finishing	Color	Application
HCN5560	V		Aluminum die casting	Powder Coating	Silver	6 series connect aluminum accessories
HCN5560K		V				
HCN5560B	V			ED Coating	Black	
HCN5560KB		V				

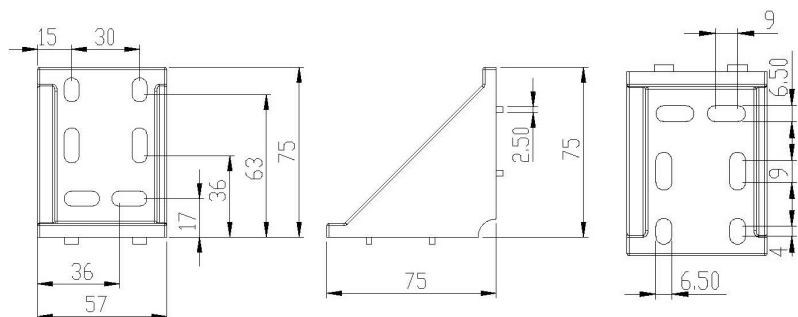

Unit: mm

Item No.	Double pin joint	No pin joint	Material	Surface finishing	Color	Application
HCN5775	V		Aluminum die casting	Powder Coating	Silver	6 series connect aluminum accessories
HCN5775K		V				
HCN5775B	V			ED Coating	Black	
HCN5775KB		V				

Triangular connection block 8 series

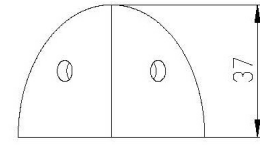
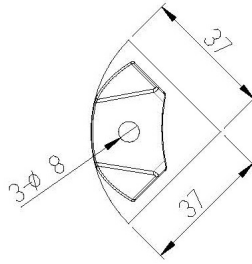

Unit: mm

Item No.	Double pin joint	No pin joint	Material	Surface finishing	Color	Application
HCN40R		V	Aluminum die casting	Powder Coating	Silver	8 series connect aluminum accessories

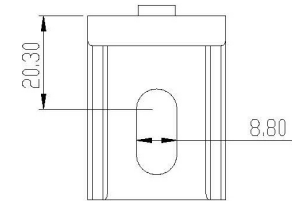
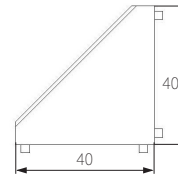
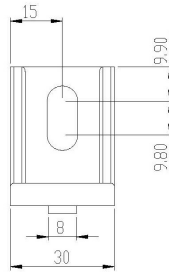

Unit: mm

Item No.	Double pin joint	No pin joint	Material	Surface finishing	Color	Application
HCN3040	V		Aluminum die casting	Powder Coating	Silver	8 series connect aluminum accessories
HCN3040K		V				
HCN3040B	V			ED Coating	Black	
HCN3040KB		V				

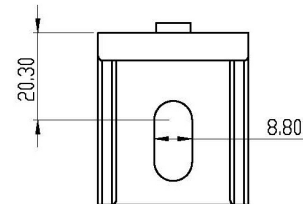
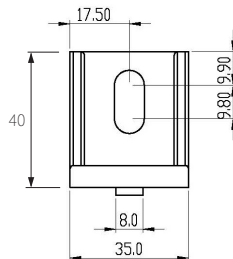

Unit: mm

Item No.	Double pin joint	No pin joint	Material	Surface finishing	Color	Application
HCN3540	V		Aluminum die casting	Powder Coating	Silver	8 series connect aluminum accessories
HCN3540K		V				
HCN3540B	V			ED Coating	Black	
HCN3540KB		V				

Triangular connection block 8 series

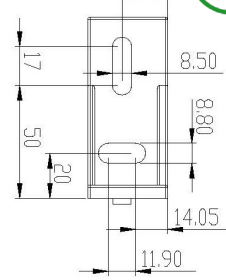
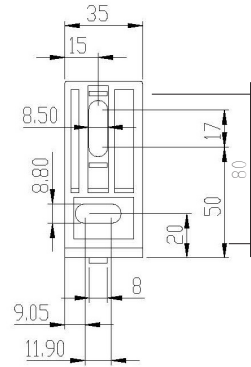
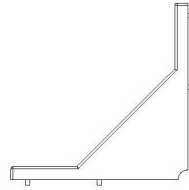

Unit: mm

Item No.	Double pin joint	No pin joint	Material	Surface finishing	Color	Application
HCN3580	V		Aluminum die casting	Powder Coating	Silver	8 series connect aluminum accessories
HCN3580K		V				
HCN3580B	V			ED Coating	Black	
HCN3580KB		V				

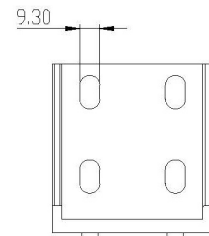
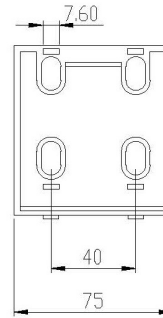
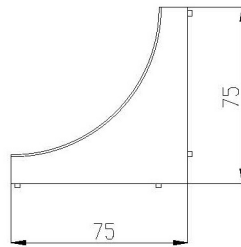

Unit: mm

Item No.	Double pin joint	No pin joint	Material	Surface finishing	Color	Application
HCN8080	V		Aluminum die casting	Powder Coating	Silver	8 series connect aluminum accessories
HCN8080K		V				
HCN8080B	V			ED Coating	Black	
HCN8080KB		V				

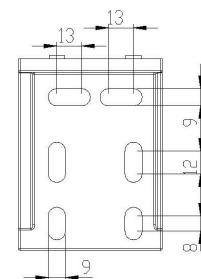
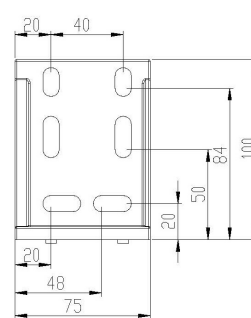
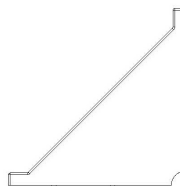

Unit: mm

Item No.	Double pin joint	No pin joint	Material	Surface finishing	Color	Application
HCN75100	V		Aluminum die casting	Powder Coating	Silver	8 series connect aluminum accessories
HCN75100K		V				
HCN75100B	V			ED Coating	Black	
HCN75100KB		V				

Triangular connection block series

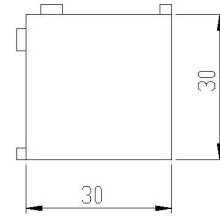
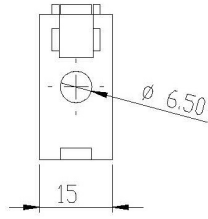

Unit: mm

Item No.	Material	Surface finishing	Color	Application
HDR1530	Aluminum die casting	Powder Coating	Silver	Applicable to door frame connector
HDR1530B		ED Coating	Black	

Hidden connection accessories series

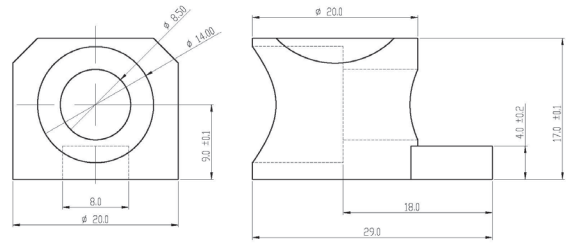
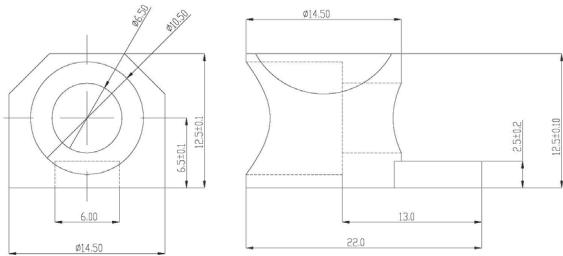

Unit: mm

Item No.	Material	Surface finishing	Color	Application
HUJ0615	Aluminum die casting	Vibration grinding	Silver	6 series connect aluminum accessories
HUJ0615B		ED Coating	Black	
HUJ0615S		Vibration grinding	Silver	6 series connect aluminum accessories (stainless steel nut inside)
HUJ0615BS		ED Coating	Black	

Unit: mm

Item No.	Material	Surface finishing	Color	Application
HUJ0820	Aluminum die casting	Vibration grinding	Silver	8 series connect aluminum accessories
HUJ0820B		ED Coating	Black	
HUJ0820S		Vibration grinding	Silver	8 series connect aluminum accessories (stainless steel nut inside)
HUJ0820BS		ED Coating	Black	

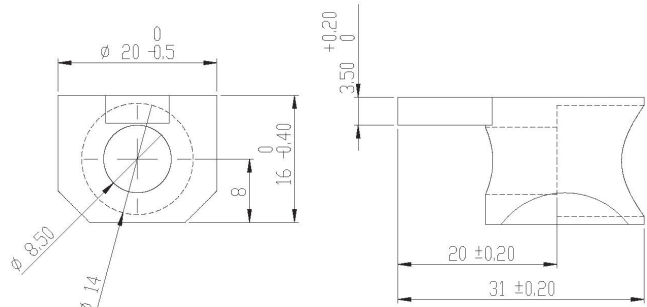
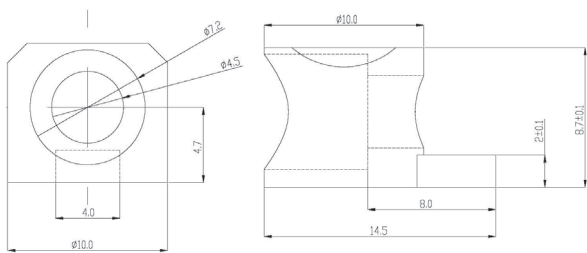

Unit: mm

Item No.	Material	Surface finishing	Color	Application
HUJ0410ZN	Zinc alloy	Bright Chrome	Gold	8 series connect aluminum accessories
HUJ0410ZNS				8 series connect aluminum accessories (stainless steel nut inside)

Unit: mm

Item No.	Material	Surface finishing	Color	Application
HUJ0820ZN	Zinc alloy	Bright Chrome	Gold	8 series connect aluminum accessories
HUJ0820ZNS				8 series connect aluminum accessories (stainless steel nut inside)

Hinge series



HTA30A / HTA30B

HTA31A / HTA31B

HTA35A / HTA35B

HTA36A / HTA36B

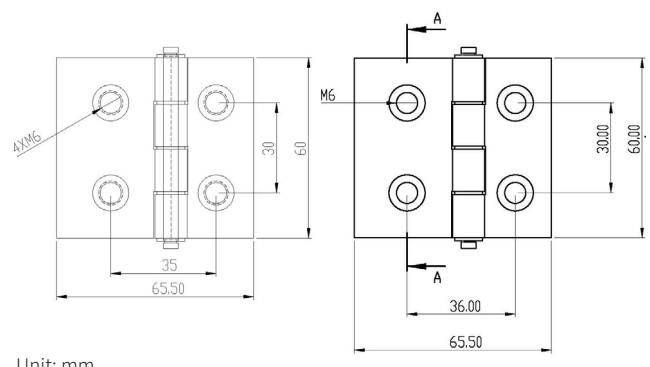
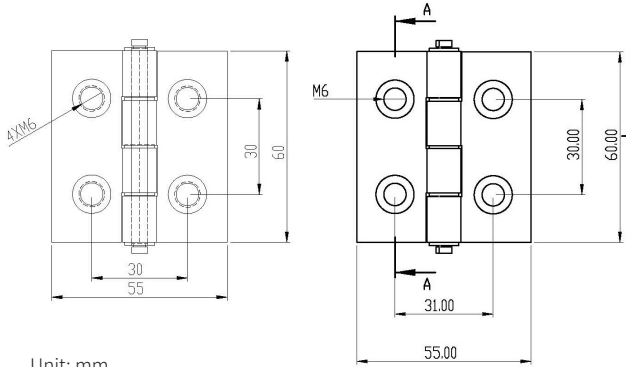

Unit: mm

Unit: mm

Item No.	Material	Surface finishing	Color	Application
HTA30A	Aluminum die casting	Anodizing	Silver	Applicable to door frame connector
HTA31A			Black	
HTA30B		ED Coating	Black	
HTA31B			Black	

Item No.	Material	Surface finishing	Color	Application
HTA35A	Aluminum die casting	Anodizing	Silver	Applicable to door frame connector
HTA36A			Black	
HTA35B		ED Coating	Black	
HTA36B			Black	



HTA40A / HTA40B

HTA41A / HTA41B

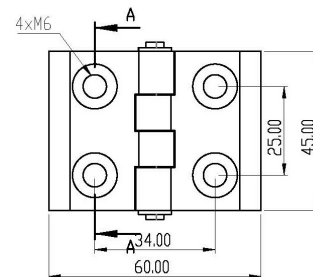
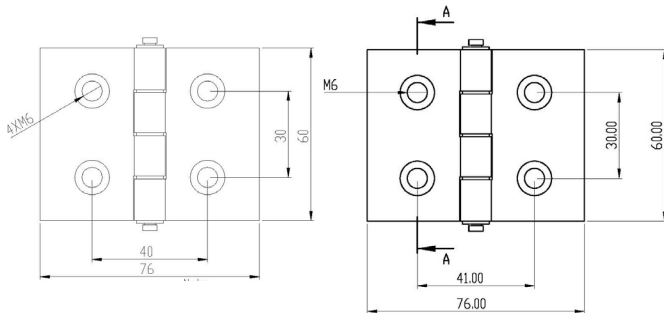

Unit: mm

Unit: mm

Item No.	Material	Surface finishing	Color	Application
HTA40A	Aluminum die casting	Anodizing	Silver	Applicable to door frame connector
HTA41A			Black	
HTA40B		ED Coating	Black	
HTA41B			Black	

Item No.	Material	Surface finishing	Color	Application
HTP34B	Nylon	Plastic injection molding	Black	Applicable to door frame connector

Connection block for fixing seal plate series

Nut insert anti-slip pad series

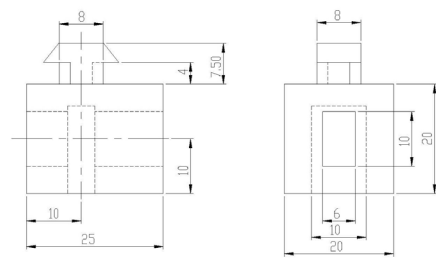
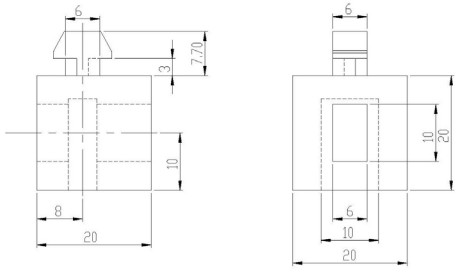

Unit: mm

Item No.	Material	Color	Application
HMB306T	PVC	Transparent	6 series aluminum accessories
HMB306G		Gray	
HMB306B		Black	

Unit: mm

Item No.	Material	Color	Application
HMB406T	PVC	Transparent	8 series aluminum accessories
HMB406G		Gray	
HMB406B		Black	

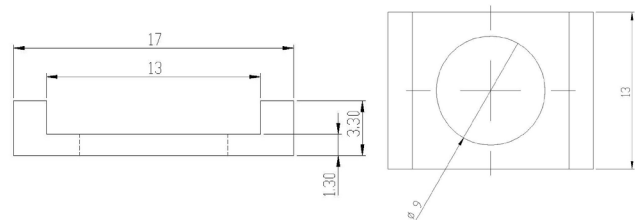
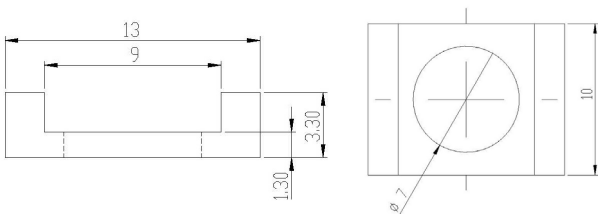

Unit: mm

Item No.	Material	Color	Application
HTHL3	PVC	Transparent	Applicable to M6 square nut

Unit: mm

Item No.	Material	Color	Application
HTHL4	PVC	Transparent	Applicable to M8 square nut

Handle series

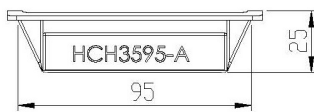
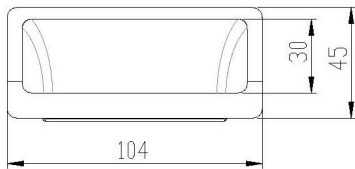

Unit: mm

Item No.	Material	Color	Application	Bolt size
HCH3595-A	Nylon	Black	Black snap-in handle 5t	95 X 40

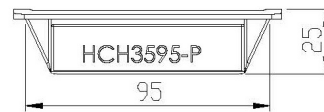
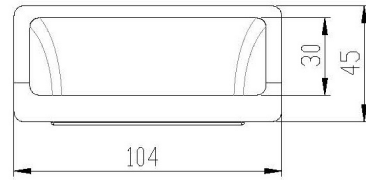

Unit: mm

Item No.	Material	Color	Application	Bolt size
HCH3595-P	Nylon	Black	Black snap-in handle 2t	95 X 40

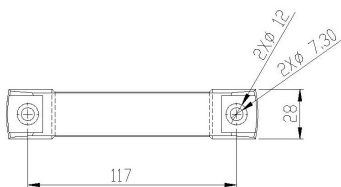
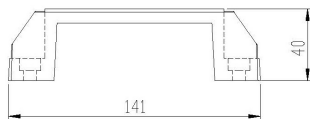

Unit: mm

Item No.	Material	Color	Application
HCH06115	Nylon	Black	Black plastic door handle P117