

CASTER

Caster selection instructions

The description of dynamic operating performance such as starting initial force, rotation and rotation ability.

Dynamic performance such as starting, rotation and rotation is mainly affected by factors such as the tread of the caster, the type of bearing, the size of the single wheel, the overall load and the environmental ground. The flexibility of dynamic control is affected by the number and installation position of casters installed on the machine equipment. The above factors will also affect the bearing capacity, turning force, guiding force, turning radius and stability of the machine equipment.

Factors contributing to low rotational resistance:

The larger the wheel diameter, the harder the tread, the better the tread resilience, the ball bearings, and the flatter the ground.

Factors contributing to low rotational resistance:

The harder the tread, the larger the tread curvature, the larger the eccentricity, and the flatter the ground.

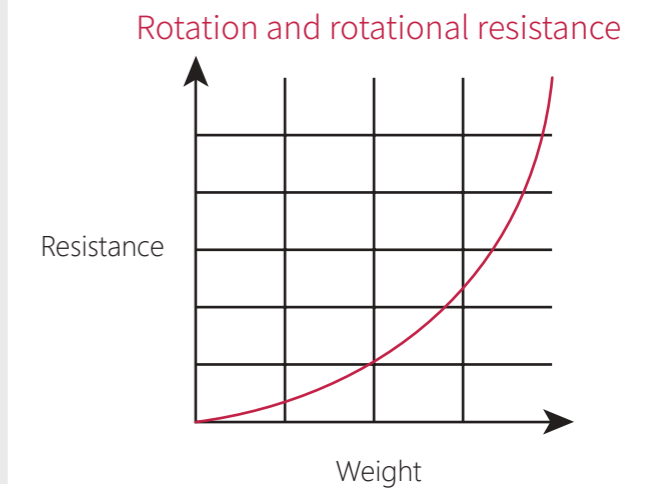

Load calculation

$$\text{Caster load capacity} = \frac{\text{The weight of the transport carrier} + \text{The weight of the carrying object}}{\text{Number of casters} \times 0.75 \text{ (safety factor)}}$$

- The above calculation method does not take into account the friction coefficient of the tire tread.
- When the traveling speed is higher than 4km/hr, it is recommended to use ball bearings.

Caster selection instructions

Material selection

The hardness, shape and tread material of the wheel are closely related to the caster's smoothness when walking, operation and flexibility when turning.

The tread hardness needs to be lower than the ground hardness in the environment in which it is used, otherwise it will cause scratches on the ground.

Reference series

Thermoplastic Rubber (TPR)	Elastic rubber (ER) High elastic polyurethane (PU)	Rubber (ER) High-temp. Resistance Nylon
<ul style="list-style-type: none"> 51 362 Light-duty stainless steel Light-duty TPR 	<ul style="list-style-type: none"> 51 62 C513 Conductive wheel 	<ul style="list-style-type: none"> 73 C2
quietness hardness	quietness hardness	quietness hardness

Polyurethane (PU)	Nylon (NY) Polypropylene (PP)
<ul style="list-style-type: none"> 62 73 C325 C430 C513 Heavy-duty caster Anti static caster GDS GSST GHP GF GXT GXTT GXTD UGXT 	<ul style="list-style-type: none"> 42 51 62 73 362 JP Light-duty Stainless Steel Low gravity high load caster Leveling Caster GF GXT GXTT GXTD UGXT
quietness hardness	quietness hardness

Heavy duty low profile caster series

Application: Medium duty machine, Heavy duty equipment, Automatic equipment, Test equipment.

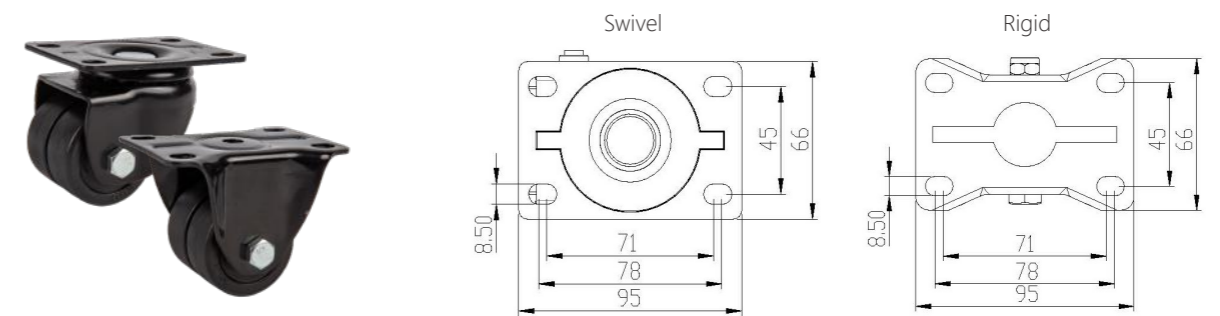

Unit: mm

Swivel Item No.	Brake Item No.	Rigid Item No.	Material	Dia. x Width	Height	Radius of gyration / brake	Load capacity (Kg)	Bearing Type
15NYTWAHD	-	15NYTWCHD	Nylon (Black)	40(1.5") x 45	62	44	130	-
2NYTWAHD	-	2NYTWCHD	ED Coating (Black)	50(2") x 45	72	49	150	

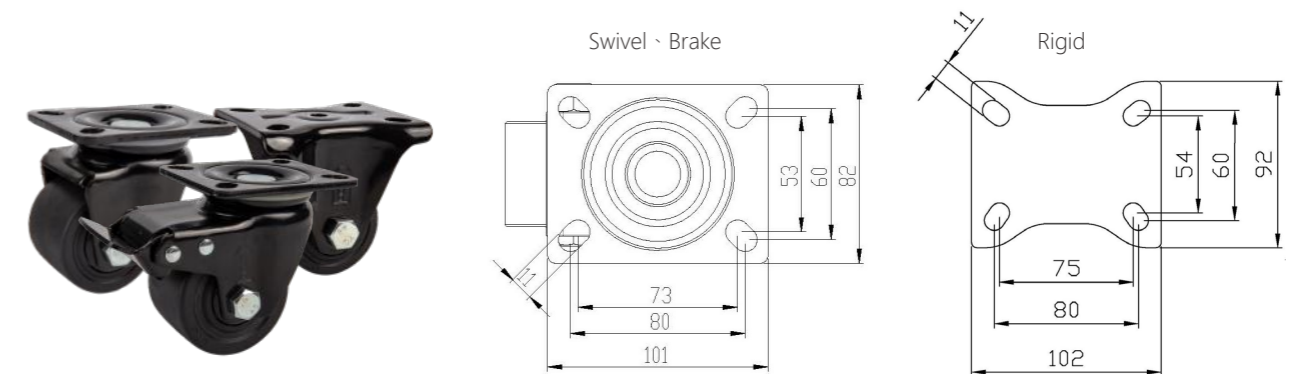

Unit: mm

Swivel Item No.	Brake Item No.	Rigid Item No.	Material	Dia. x Width	Height	Radius of gyration / brake	Load capacity (Kg)	Bearing Type
2JPAHD	2JPBHD	2JPCHD	Nylon (Black) ED Coating (Black)	50(2") x 50	83	52 / 94	300	6202 x 2
25JPAHD	25JPBHD	25JPCHD		63(2.5") x 50	96	58 / 98	600	
3JPAHD	3JPBHD	3JPCHD		75(3") x 50	108	68 / 108	800	
4JPAHD	-	4JPCHD		100(4") x 50	136.5	86	800	

Heavy duty low profile caster series

Application: Medium duty machine, Heavy duty equipment, Automatic equipment, Test equipment.

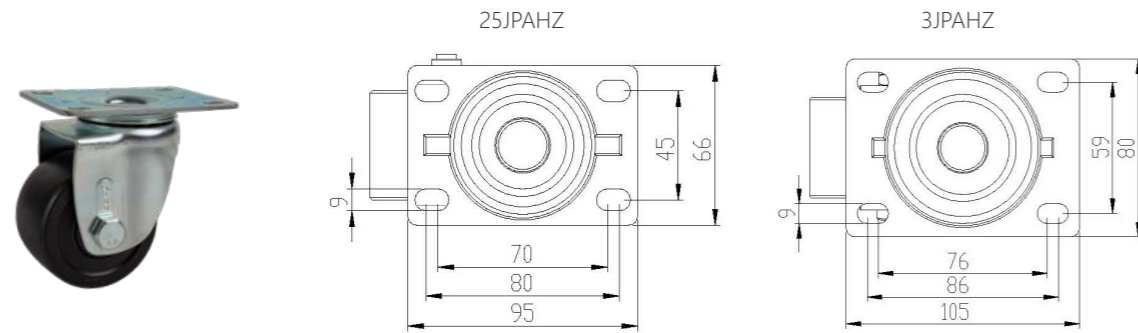

Unit: mm

Swivel Item No.	Brake Item No.	Rigid Item No.	Material	Dia. x Width	Height	Radius of gyration / brake	Load capacity (Kg)	Bearing Type
25JPAHZ	-	-	Nylon (Black) SS41	63(2.5") X 45	85	57	200	6002 x 2
3JPAHZ	-	-		75(3") X 45	105	64	250	

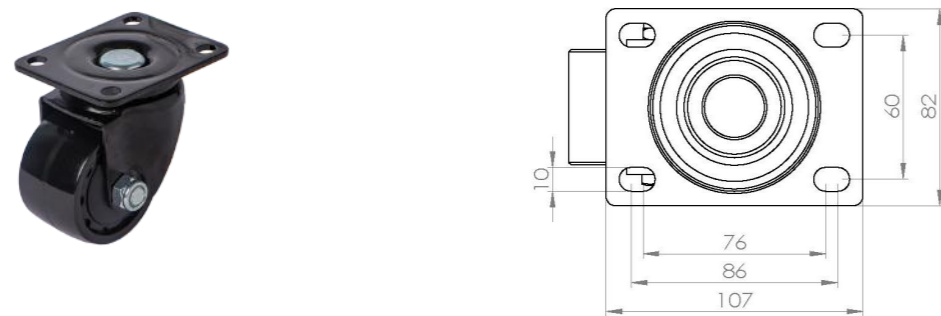

Unit: mm

Swivel Item No.	Brake Item No.	Rigid Item No.	Material	Dia. x Width	Height	Radius of gyration / brake	Load capacity (Kg)	Bearing Type
3MCHDA	-	-	Nylon (Black) Powder Coating (Black)	75(3") X 50	104	69	600	6202 x 2

Light duty JP series

Application: Medium duty machine, Heavy duty equipment, Automatic equipment, Test equipment.



Unit: mm

Swivel Item No.	Brake Item No.	Rigid Item No.	Material	Dia. x Width	Height	Radius of gyration / brake	Load capacity (Kg)	Bearing Type
2JPAT	-	-	Nylon (Black) Bright Chrome	46(2") X 38	73	50	250	6201 x 2

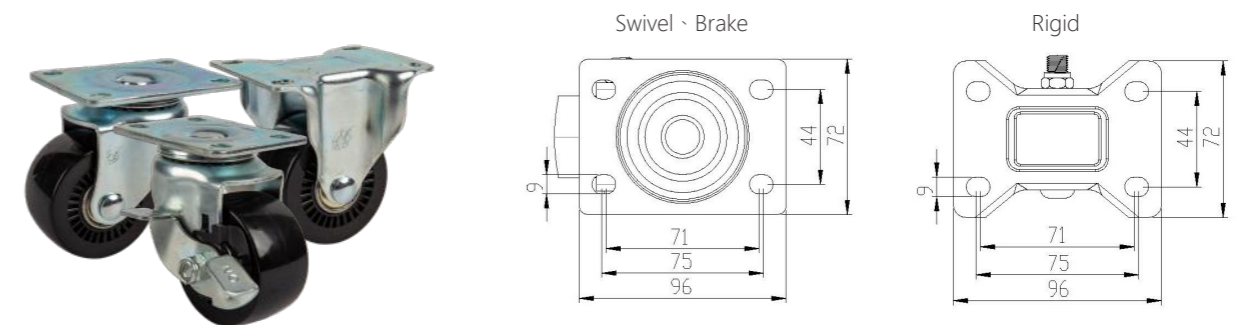

Unit: mm

Swivel Item No.	Brake Item No.	Rigid Item No.	Material	Dia. x Width	Height	Radius of gyration / brake	Load capacity (Kg)	Bearing Type
25JPA	25JPB	25JPC	Nylon (Black) SS41	62(2.5") X 38	93	60 / 78	150	-
25JPAT	25JPBT	25JPCT					250	6201 x 2
3JPASH	3JPBSH	-		75(3") X 38	105	66 / 78		

Light duty JP series

Application: Medium duty machine, Heavy duty equipment, Automatic equipment, Test equipment.

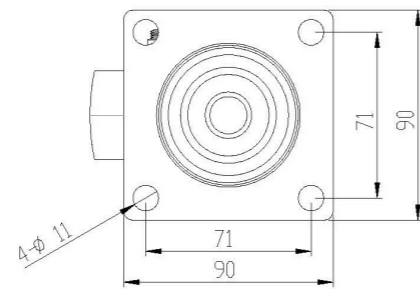

Unit: mm

Swivel Item No.	Brake Item No.	Rigid Item No.	Material	Dia. x Width	Height	Radius of gyration / brake	Load capacity (Kg)	Bearing Type
25JPATSQ	25JPBTSQ	-	Nylon (Black) SS41	62(2.5") X 38	94	60 / 78	250	6201 x 2
3JPASQ	3JPBSQ	-		75(3") X 38	105	66 / 78		

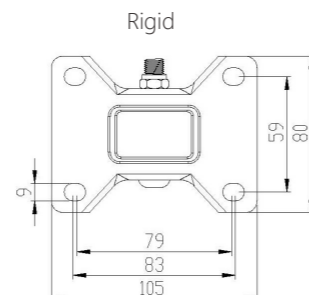
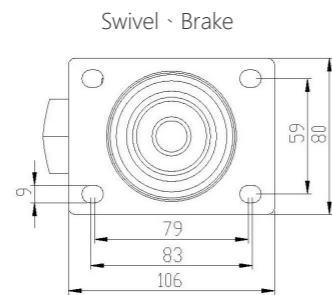

Unit: mm

Swivel Item No.	Brake Item No.	Rigid Item No.	Material	Dia. x Width	Height	Radius of gyration / brake	Load capacity (Kg)	Bearing Type
3JPA	3JPB	3JPC	Nylon (Black) SS41	75(3") X 38	105	67 / 78	250	6201 x 2

Light duty JP series

Application: Medium duty machine, Heavy duty equipment, Automatic equipment, Test equipment.

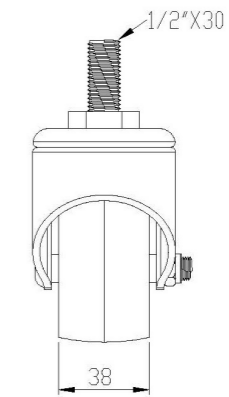

Unit: mm

Swivel Item No.	Brake Item No.	Rigid Item No.	Material	Dia. x Width	Height	Radius of gyration / brake	Load capacity (Kg)	Bearing Type
25JP4A	25JP4B	-	Nylon (Black) SS41	62(2.5") X 38	97	60 / 78	150	-
25JP4AT	25JP4BT	-					250	6201 x 2

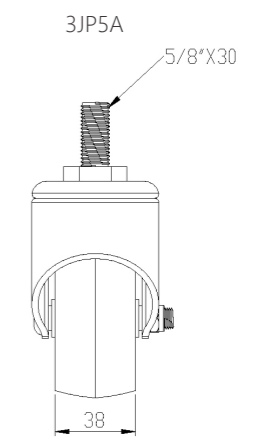
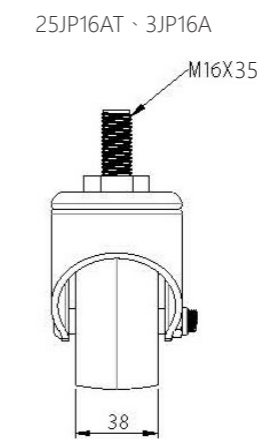

Unit: mm

Swivel Item No.	Brake Item No.	Rigid Item No.	Material	Dia. x Width	Height	Radius of gyration / brake	Load capacity (Kg)	Bearing Type
25JP16AT	25JP16BT	-	Nylon (Black) SS41	62(2.5") X 38	97	60 / 78	250	6201 x 2
3JP16A	3JP16B	-		75(3") X 38	109	66 / 78		
3JP5A	3JP5B	-						

Light duty 42 series

Application: trolleys for electronics factories, automation equipment, precision instruments and equipment, food machinery and equipment

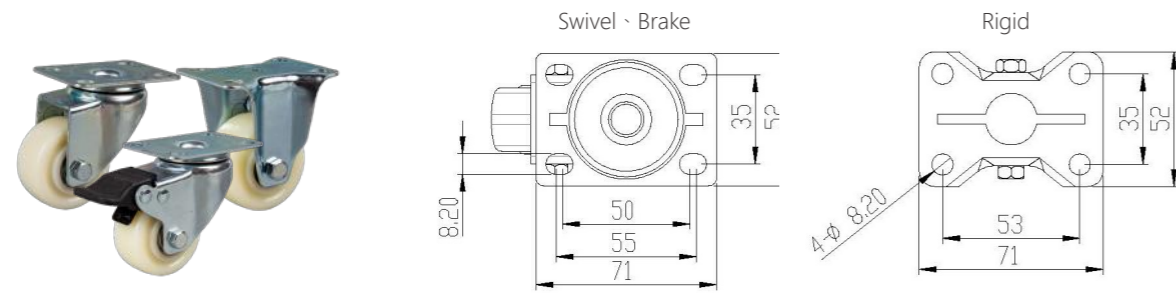

Unit: mm

Swivel Item No.	Brake Item No.	Rigid Item No.	Material	Dia. x Width	Height	Radius of gyration / brake	Load capacity (Kg)	Bearing Type
2NYH42A	2NYH42B	2NYH42C	Nylon (White) SS41	50(2") X 26	75	53 / 76	60	608Z x 2

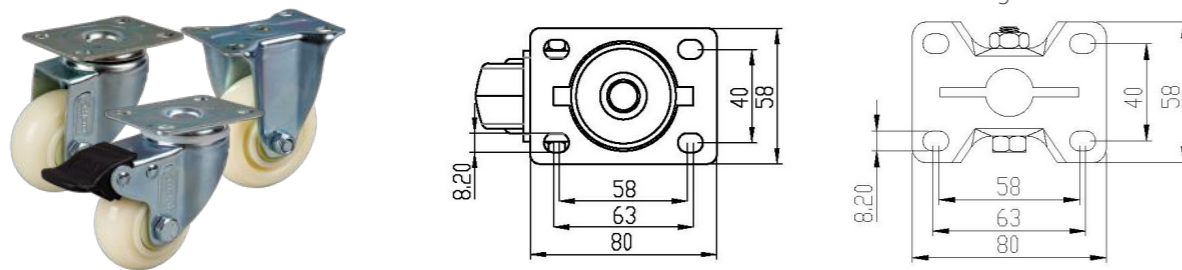

Unit: mm

Swivel Item No.	Brake Item No.	Rigid Item No.	Material	Dia. x Width	Height	Radius of gyration / brake	Load capacity (Kg)	Bearing Type
25NYH42A	25NYH42B	25NYH42C	Nylon (White) SS41	62(2.5") X 28	92	63.5 / 93	80	6001ZZ x 2
3NYH42A	3NYH42B	3NYH42C		75(3") X 28	103	69.5 / 96		

Light duty 42 series

Application: trolleys for electronics factories, automation equipment, precision instruments and equipment, food machinery and equipment



Unit: mm

Swivel Item No.	Brake Item No.	Rigid Item No.	Material	Dia. x Width	Height	Radius of gyration / brake	Load capacity (Kg)	Bearing Type
2NYH4210A	2NYH4210B	-	Nylon (White) SS41	50(2") X 25	77	53 / 76	50	608Z x 2



Unit: mm

Swivel Item No.	Brake Item No.	Rigid Item No.	Material	Dia. x Width	Height	Radius of gyration / brake	Load capacity (Kg)	Bearing Type
25NYH4212A	25NYH4212B	-	Nylon (White) SS41	62(2.5") X 28	91.5	63.5 / 93	70	6001ZZ x 2
3NYH4212A	3NYH4212B	-		75(3") X 28	106.5	69.5 / 96		

Light duty 51 series

Application: trolleys for electronics factories, automation equipment, precision instruments and equipment, food machinery and equipment

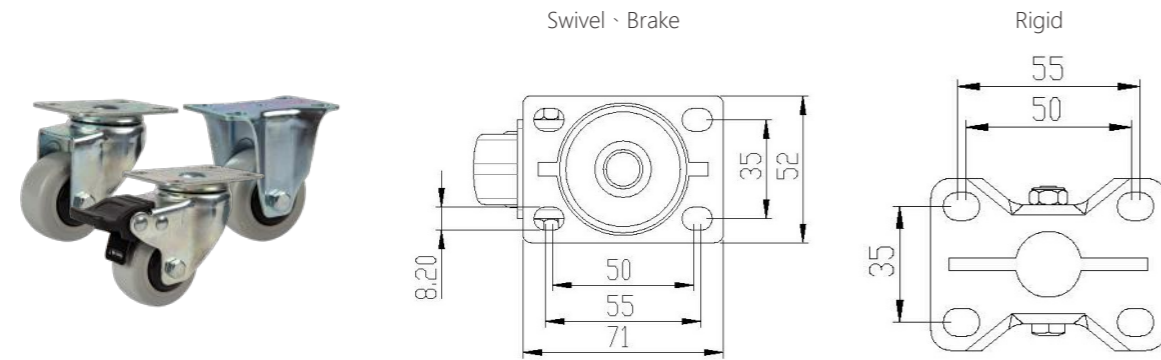

Unit: mm

Swivel Item No.	Brake Item No.	Rigid Item No.	Material	Dia. x Width	Height	Radius of gyration / brake	Load capacity (Kg)	Bearing Type
2PPH51A	2PPH51B	2PPH51C	PP SS41	50(2") X 26	75	53 / 76	55	6002ZZ x 1



Unit: mm

Swivel Item No.	Brake Item No.	Rigid Item No.	Material	Dia. x Width	Height	Radius of gyration / brake	Load capacity (Kg)	Bearing Type
2PPH5110A	2PPH5110B	-	PP SS41	50(2") X 26	77	53 / 76	55	6002ZZ x 1

Light duty 51 series

Application: trolleys for electronics factories, automation equipment, precision instruments and equipment, food machinery and equipment



Unit: mm

Swivel Item No.	Brake Item No.	Rigid Item No.	Material	Dia. x Width	Height	Radius of gyration / brake	Load capacity (Kg)	Bearing Type
25PPH51A	25PPH51B	25PPH51C	PP SS41	62(2.5") X 32	94	67 / 102	100	6002ZZ x 1
3PPH51A	3PPH51B	3PPH51C		75(3") X 32	106	73 / 102	120	
4PPH51A	4PPH51B	4PPH51C		100(4") X 32	131	85.5 / 107	140	
3ERH51A	3ERH51B	3ERH51C	Rubber SS41	75(3") X 32	106	73 / 102	80	
4ERH51A	4ERH51B	4ERH51C		100(4") X 32	131	85.5 / 107	100	
5ERH51A	5ERH51B	5ERH51C		125(5") X 32	157	101 / 113	100	
25PRH51A	25PRH51B	25PRH51C	TPR SS41	62(2.5") X 32	94	67 / 102	100	
3PRH51A	3PRH51B	3PRH51C		75(3") X 32	106	73 / 102	120	
4PRH51A	4PRH51B	4PRH51C		100(4") X 32	131	85.5 / 107	140	

Light duty 51 series

Application: trolleys for electronics factories, automation equipment, precision instruments and equipment, food machinery and equipment

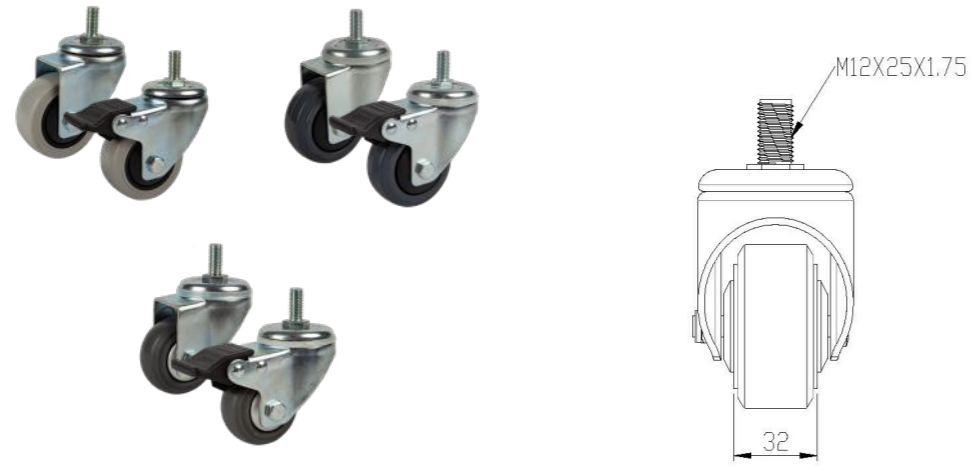

Unit: mm

Swivel Item No.	Brake Item No.	Rigid Item No.	Material	Dia. x Width	Height	Radius of gyration / brake	Load capacity (Kg)	Bearing Type
25PPH5112A	25PPH5112B	-	PP SS41	62(2.5") X 32	94	67 / 102	100	6002ZZ x 1
3PPH5112A	3PPH5112B	-		75(3") X 32	106	73 / 102	120	
4PPH5112A	4PPH5112B	-		100(4") X 32	131	85.5 / 107	140	
3ERH5112A	3ERH5112B	-	Rubber SS41	75(3") X 32	106	73 / 102	80	
4ERH5112A	4ERH5112B	-		100(4") X 32	131	85.5 / 107	100	
5ERH5112A	5ERH5112B	-		125(5") X 32	157	101 / 113	100	
25PRH5112A	25PRH5112B	-	TPR SS41	62(2.5") X 32	94	67 / 102	100	
3PRH5112A	3PRH5112B	-		75(3") X 32	106	73 / 102	120	
4PRH5112A	4PRH5112B	-		100(4") X 32	131	85.5 / 107	140	

Medium duty 62 series

Application: trolleys for electronics factories, automation equipment, precision instruments and equipment, food machinery and equipment, conveyor equipment

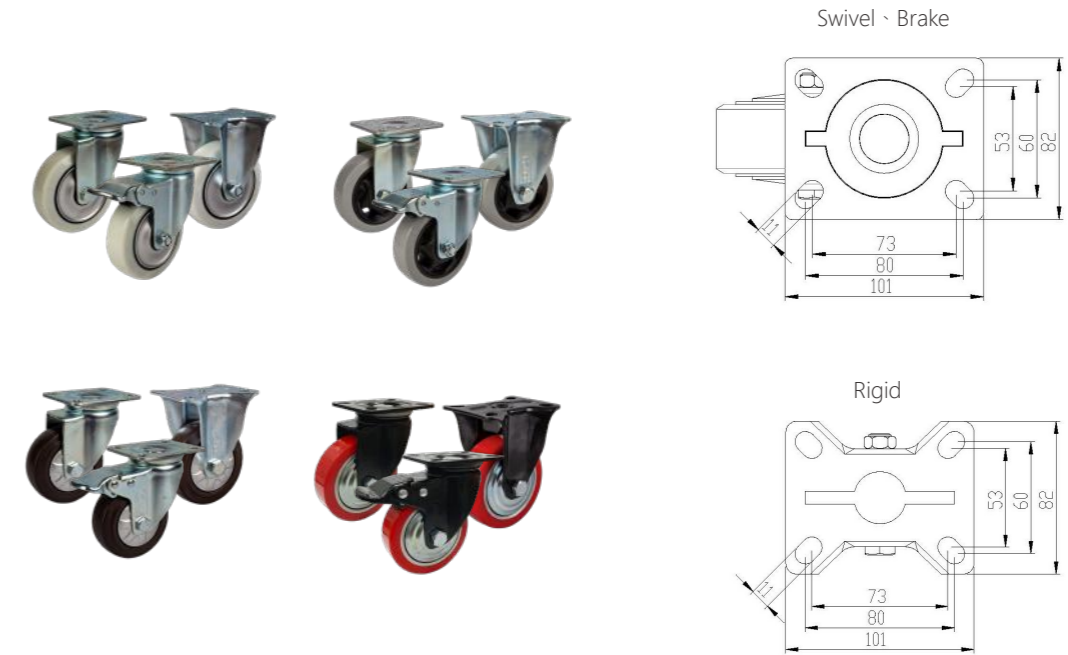

Unit: mm

Swivel Item No.	Brake Item No.	Rigid Item No.	Material	Dia. x Width	Height	Radius of gyration / brake	Load capacity (Kg)	Bearing Type
4NYH62A	4NYH62B	4NYH62C	Nylon(White) SS41	100(4") X 38	136	85 / 109	250	6202ZZ x 2
4PPH62A	4PPH62B	4PPH62C	PP SS41				135	
4ERH62A	4ERH62B	4ERH62C	Rubber SS41				300	
4PUH62A-B	4PUH62B-B	4PUH62C-B	PU (Red) ED Coating					

Medium duty 62 series

Application: trolleys for electronics factories, automation equipment, precision instruments and equipment, food machinery and equipment, conveyor equipment

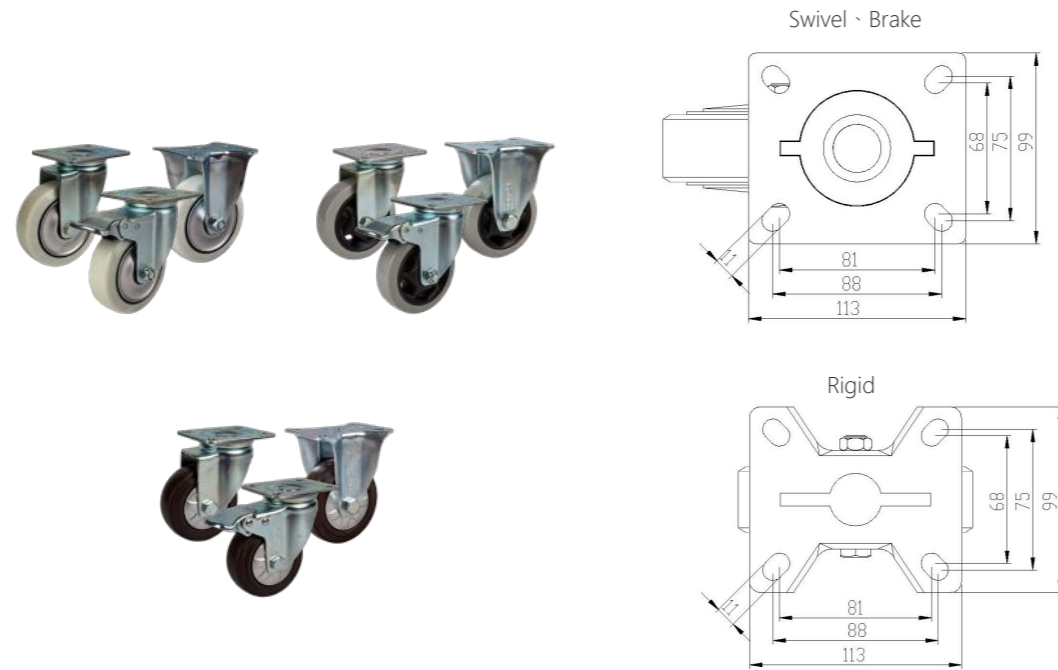

Unit: mm

Swivel Item No.	Brake Item No.	Rigid Item No.	Material	Dia. x Width	Height	Radius of gyration / brake	Load capacity (Kg)	Bearing Type
5NYH62A	5NYH62B	5NYH62C	Nylon(White) SS41	125(5") X 38	163	102.5/124.5	300	6202ZZ x 2
6NYH62A	6NYH62B	6NYH62C		150(6") X 38	190	119/129.5		
5PPH62A	5PPH62B	5PPH62C	PP SS41	125(5") X 38	163	102.5/124.5		
6PPH62A	6PPH62B	6PPH62C		150(6") X 38	190	119/129.5		
5ERH62A	5ERH62B	5ERH62C	Rubber SS41	125(5") X 38	163	102.5/124.5	160	
6ERH62A	6ERH62B	6ERH62C		150(6") X 38	190	119/129.5	175	

Medium duty 73 series

Application: Medium duty machine, Heavy duty equipment, Automatic equipment, Test equipment.

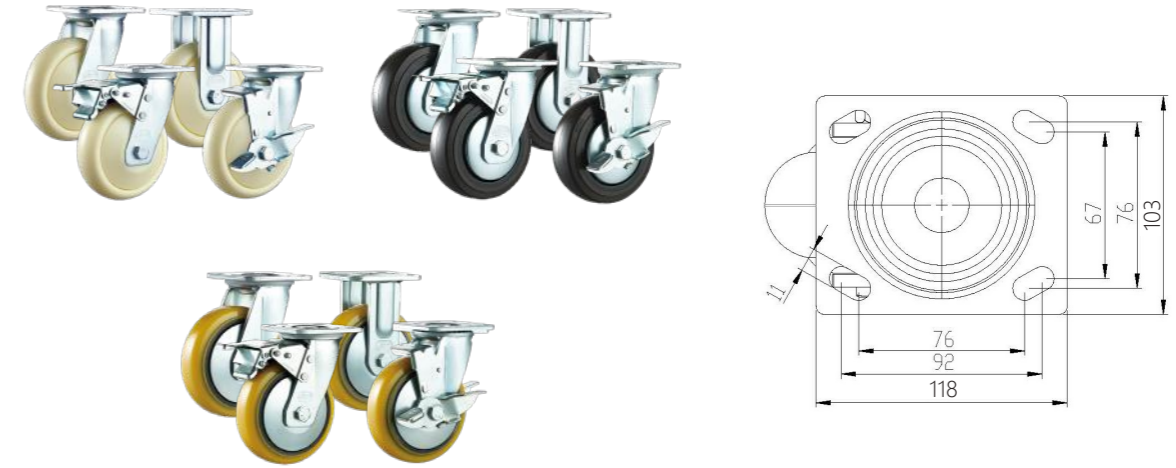

Unit: mm

Swivel Item No.	Brake Item No.	Side Brake Item No.	Rigid Item No.	Material	Dia. x Width	Height	Radius of gyration / brake (Side Brake)	Load capacity (Kg)	Bearing Type
4NYH73A	4NYH73B	4NYH73KB	4NYH73C	Nylon (White) SS41	100(4") X 50	144	81/129(91)	300	6202 X 2
5NYH73A	5NYH73B	5NYH73KB	5NYH73C		125(5") X 50	165	96/129(96)	350	
6NYH73A	6NYH73B	6NYH73KB	6NYH73C		150(6") X 50	191	115/141(115)	400	
8NYH73A	8NYH73B	8NYH73KB	8NYH73C		200(8") X 50	242	150/150(150)	400	
4ERH73A	4ERH73B	4ERH73KB	4ERH73C	Rubber SS41	100(4") X 48	144	81/129(91)	200	
5ERH73A	5ERH73B	5ERH73KB	5ERH73C		125(5") X 48	165	96/129(96)	250	
6ERH73A	6ERH73B	6ERH73KB	6ERH73C		150(6") X 48	191	115/141(115)	340	
8ERH73A	8ERH73B	8ERH73KB	8ERH73C		200(8") X 48	242	150/150(150)	390	
4PUH73A	4PUH73B	4PUH73KB	4PUH73C	PU SS41	100(4") X 48	144	81/129(91)	300	6203 X 2
5PUH73A	5PUH73B	5PUH73KB	5PUH73C		125(5") X 48	165	96/129(96)	400	
6PUH73A	6PUH73B	6PUH73KB	6PUH73C		150(6") X 48	191	115/141(115)	400	
8PUH73A	8PUH73B	8PUH73KB	8PUH73C		200(8") X 48	242	150/150(150)	500	

Light duty polyurethane C325-UA series

Application: Medium duty machine, Heavy duty equipment, Automatic equipment, Test equipment.

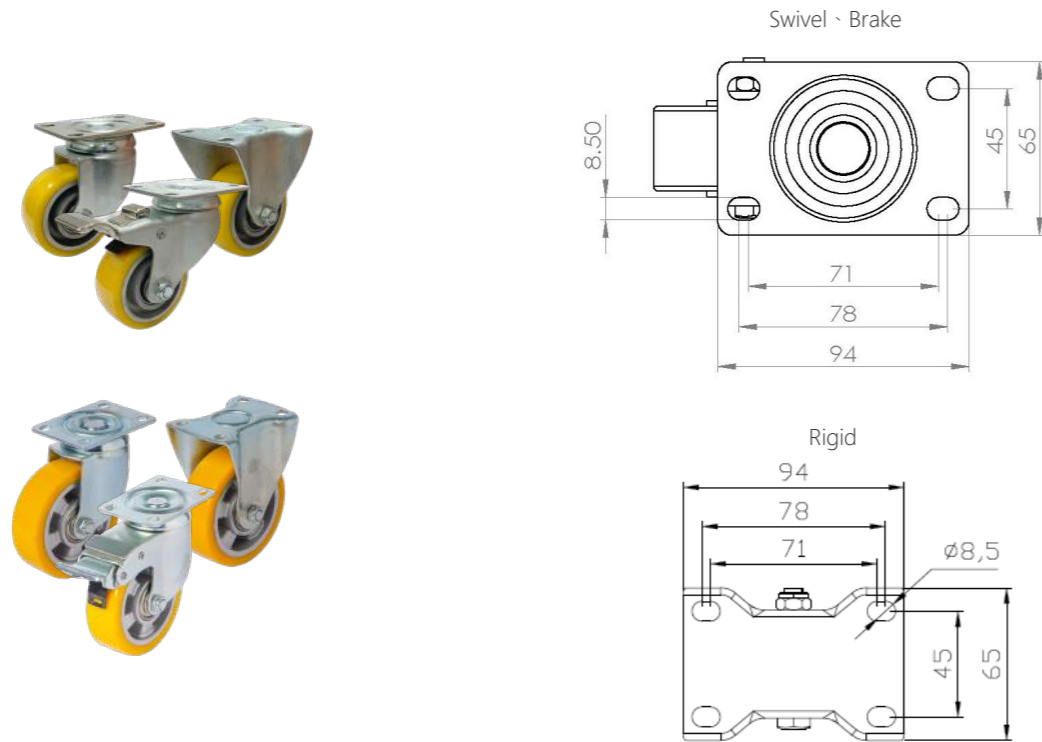

Unit: mm

Swivel Item No.	Brake Item No.	Rigid Item No.	Material	Dia. x Width	Height	Radius of gyration / brake	Load capacity (Kg)	Bearing Type
3UAC325HDA	3UAC325HDB	3UAC325HDC	PU(93A) Aluminum Core SS41	75(3") X 32	106	71 / 117	100	6002 X 2
4UAC325HDA	4UAC325HDB	4UAC325HDC		100(4") X 32	131	83.5 / 117	150	
5UAC325HDA	5UAC325HDB	5UAC325HDC		125(5") X 32	159	96 / 117	180	

Medium duty polyurethane C513-UA series

Application: Medium duty machine, Heavy duty equipment, Automatic equipment, Test equipment.

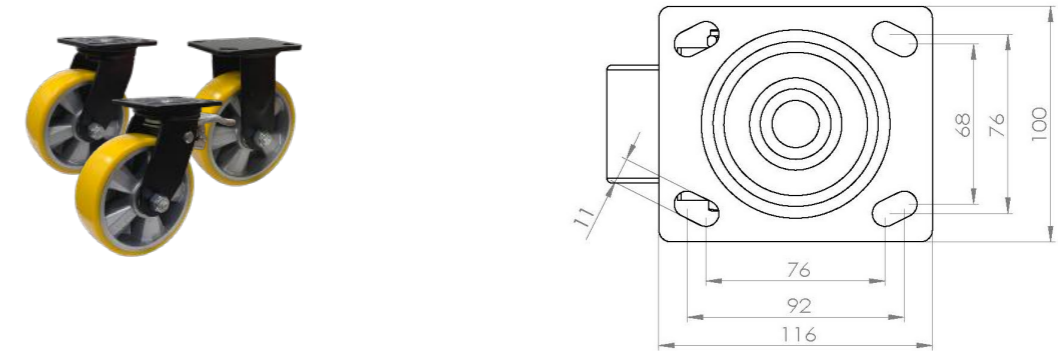

Unit: mm

Swivel Item No.	Brake Item No.	Rigid Item No.	Material	Dia. x Width	Height	Radius of gyration / brake	Load capacity (Kg)	Bearing Type
4UAC513HDA	4UAC513HDB	4UAC513HDC	PU(93A) Aluminum Core Powder Coating (Black)	100(4") X 50	142	80 / 150	250	6203 X 2
5UAC513HDA	5UAC513HDB	5UAC513HDC		125(5") X 50	167	99 / 150	350	
6UAC513HDA	6UAC513HDB	6UAC513HDC		150(6") X 50	189	124 / 150	450	
8UAC513HDA	8UAC513HDB	8UAC513HDC		200(8") X 50	239	150 / 150	600	

Medium duty polyurethane C513-UART series

Application: Medium duty machine, Heavy duty equipment, Automatic equipment, Test equipment.

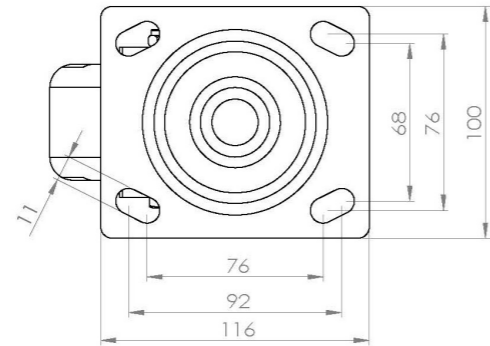

Unit: mm

Swivel Item No.	Brake Item No.	Rigid Item No.	Material	Dia. x Width	Height	Radius of gyration / brake	Load capacity (Kg)	Bearing Type
4UARTC513HDA	4UARTC513HDB	4UARTC513HDC	PU(93A) Aluminum Core Powder Coating (Black)	100(4") X 50	142	80 / 150	250	6203 X 2
5UARTC513HDA	5UARTC513HDB	5UARTC513HDC		125(5") X 50	167	99 / 150	350	
6UARTC513HDA	6UARTC513HDB	6UARTC513HDC		150(6") X 50	189	124 / 150	450	
8UARTC513HDA	8UARTC513HDB	8UARTC513HDC		200(8") X 50	239	150 / 150	600	

Medium duty polyurethane C513-EMA series

Application: Medium duty machine, Heavy duty equipment, Automatic equipment, Test equipment.

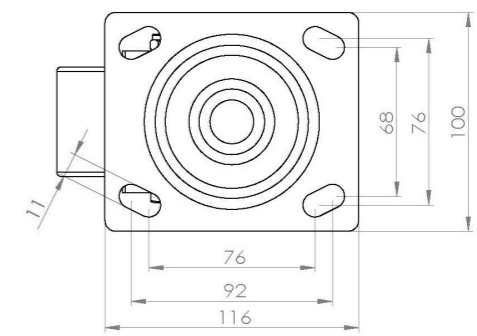

Unit: mm

Swivel Item No.	Brake Item No.	Rigid Item No.	Material	Dia. x Width	Height	Radius of gyration / brake	Load capacity (Kg)	Bearing Type
4EMAC513HDA	4EMAC513HDB	4EMAC513HDC	PU(78A) Aluminum Core Powder Coating (Black)	100(4") X 50	142	80 / 150	250	6203 X 2
5EMAC513HDA	5EMAC513HDB	5EMAC513HDC		125(5") X 50	167	99 / 150	300	
6EMAC513HDA	6EMAC513HDB	6EMAC513HDC		150(6") X 50	189	124 / 150	350	
8EMAC513HDA	8EMAC513HDB	8EMAC513HDC		200(8") X 50	239	150 / 150	450	

Medium duty polyurethane C430 series

Application: Medium duty machine, Heavy duty equipment, Automatic equipment, Test equipment.

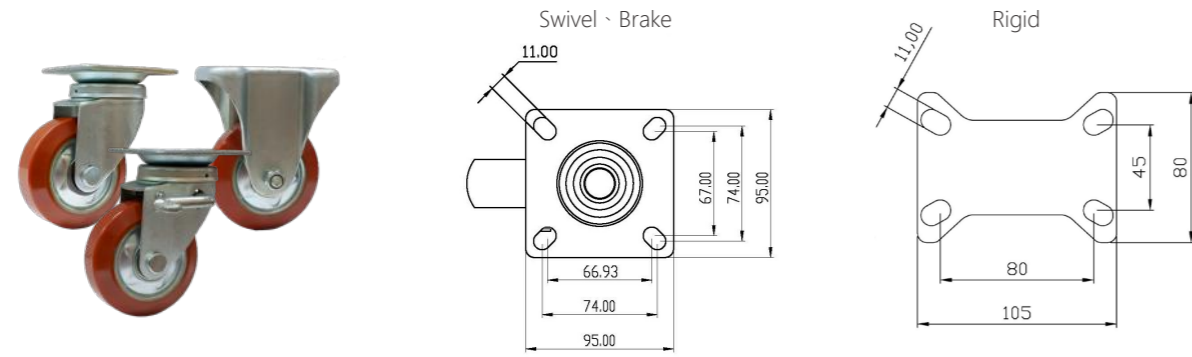

Unit: mm

Swivel Item No.	Brake Item No.	Rigid Item No.	Material	Dia. x Width	Height	Radius of gyration / brake	Load capacity (Kg)	Bearing Type
4PUC430A	4PUC430BR	4PUC430C	PU SS41	100(4") X 35	144	85 / 85	200	6303 X 2

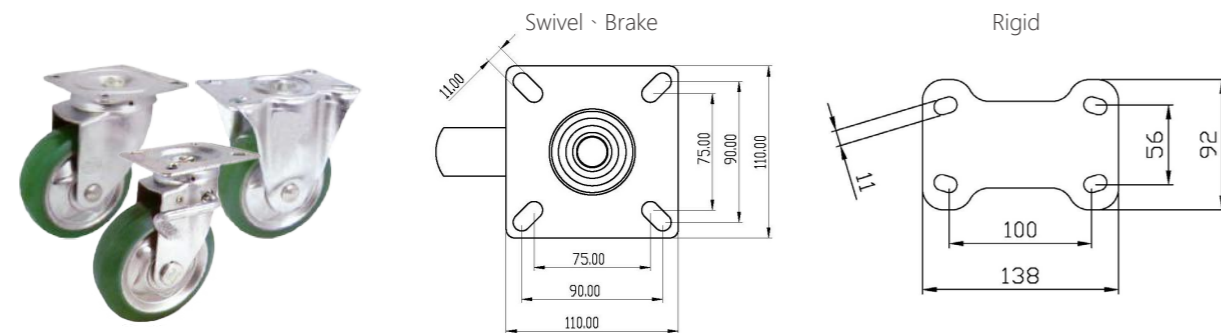

Unit: mm

Swivel Item No.	Brake Item No.	Rigid Item No.	Material	Dia. x Width	Height	Radius of gyration / brake	Load capacity (Kg)	Bearing Type
5PUC430A	5PUC430BR	5PUC430C	PU SS41	130(5") X 42	177	103 / 107	250	6303 X 2

Medium duty chrome plated K series

Application: Medium duty machine, Heavy duty equipment, Automatic equipment, Test equipment.

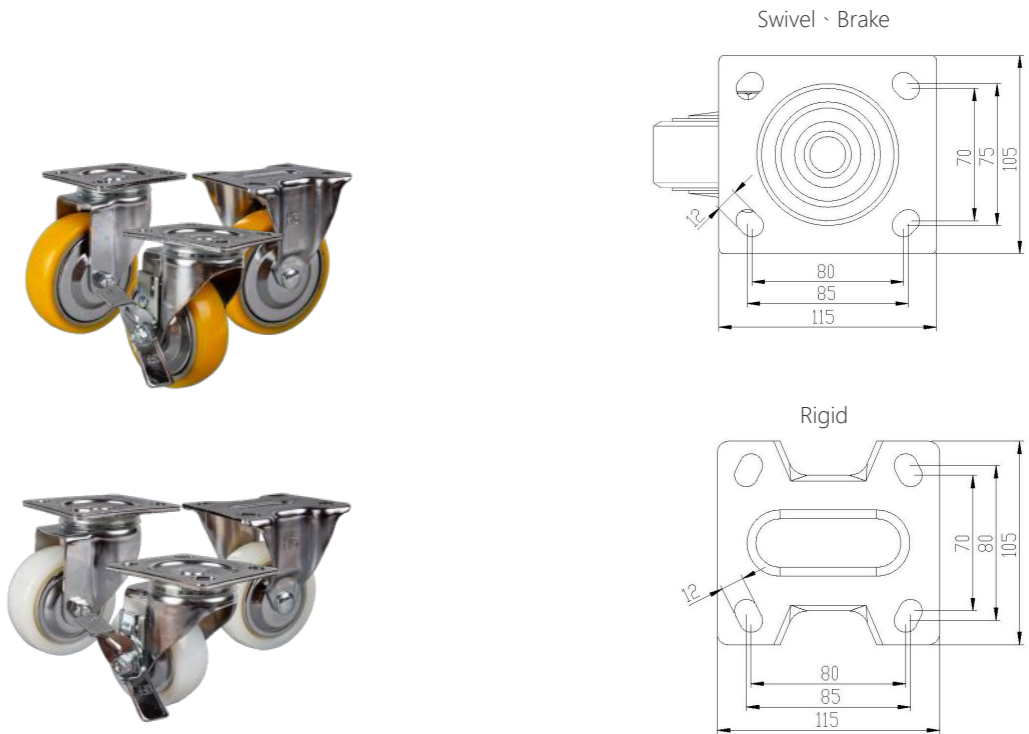

Unit: mm

Swivel Item No.	Brake Item No.	Rigid Item No.	Material	Dia. x Width	Height	Radius of gyration / brake	Load capacity (Kg)	Bearing Type
4PUKA	4PUKB	4PUKC	PU Bright Chrome	100(4") X 38	138	92 / 92	300	6202 X 2
5PUKA	5PUKB	5PUKC		125(5") X 38	165	105 / 105		
6PUKA	6PUKB	6PUKC		150(6") X 38	190	117 / 117		
4NYKA	4NYKB	4NYKC	Nylon (White) Bright Chrome	100(4") X 38	138	92 / 92		
5NYKA	5NYKB	5NYKC		125(5") X 38	165	105 / 105		
6NYKA	6NYKB	6NYKC		150(6") X 38	190	117 / 117		

Heavy duty series

Application: Medium duty machine, Heavy duty equipment, Automatic equipment, Test equipment.

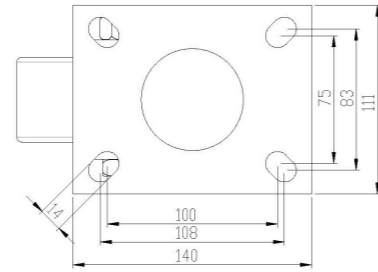

Unit: mm

Swivel Item No.	Brake Item No.	Rigid Item No.	Material	Dia. x Width	Height	Radius of gyration / brake	Load capacity (Kg)	Bearing Type
5PUHDA	5PUHDB	5PUHDC	PU Powder Coating	125(5") X 50	177	103 / 135	600	6303 X 2
6PUHDA	6PUHDB	6PUHDC		150(6") X 50	201	118 / 135	700	
8PUHDA	8PUHDB	8PUHDC		200(8") X 50	250	150 / 150	800	
5NYHDA	5NYHDB	5NYHDC	Nylon (White) Powder Coating	125(5") X 50	177	103 / 135	600	6003 X 2
6NYHDA	6NYHDB	6NYHDC		150(6") X 50	201	118 / 135	700	
8NYHDA	8NYHDB	8NYHDC		200(8") X 50	250	150 / 150	800	

Light duty TPR series

Application: Various medical equipment carts, catering equipment carts, conveyor equipment, light-load trolleys, various display racks in stores, and small cabinets.

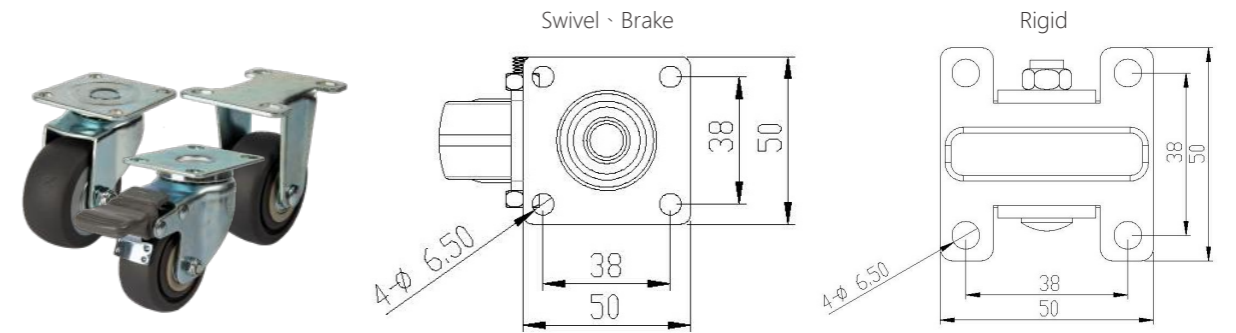

Unit: mm

Swivel Item No.	Brake Item No.	Rigid Item No.	Material	Dia. x Width	Height	Radius of gyration / brake	Load capacity (Kg)	Bearing Type
2PRA	2PRB	2PRC	TPR SS41	50(2") X 23	67	50 / 75	50	608Z X 2



Unit: mm

Swivel Item No.	Brake Item No.	Rigid Item No.	Material	Dia. x Width	Height	Radius of gyration / brake	Load capacity (Kg)	Bearing Type
2PR3A	2PR3B	-	TPR SS41	50(2") X 23	69	50 / 75	50	608Z X 2

Light duty TPR series

Application: Various medical equipment carts, catering equipment carts, conveyor equipment, light-load trolleys, various display racks in stores, and small cabinets.

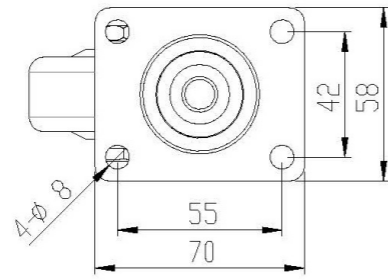

Unit: mm

Swivel Item No.	Brake Item No.	Rigid Item No.	Material	Dia. x Width	Height	Radius of gyration / brake	Load capacity (Kg)	Bearing Type
25PRA	25PRB	25PRC	TPR SS41	63(2.5") X 25	87	57 / 90	70	608Z X 2
3PRMASH	3PRMBSH	-		75(3") X 25	104	63 / 90		

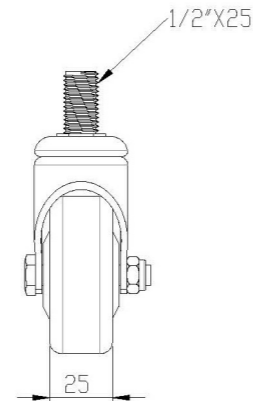

Unit: mm

Swivel Item No.	Brake Item No.	Rigid Item No.	Material	Dia. x Width	Height	Radius of gyration / brake	Load capacity (Kg)	Bearing Type
25PR4A	25PR4B	-	TPR SS41	63(2.5") X 25	88	57 / 90	70	608Z X 2
3PRM4A	3PRM4B	-		75(3") X 25	105	63 / 90		

Light duty TPR series

Application: Various medical equipment carts, catering equipment carts, conveyor equipment, light-load trolleys, various display racks in stores, and small cabinets.

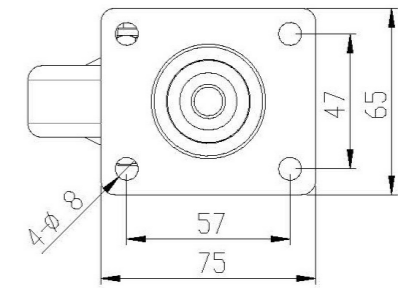

Unit: mm

Swivel Item No.	Brake Item No.	Rigid Item No.	Material	Dia. x Width	Height	Radius of gyration / brake	Load capacity (Kg)	Bearing Type
3PRMA	3PRMB	3PRMC	TPR SS41	75(3") X 25	104	63 / 90	70	608Z X 2

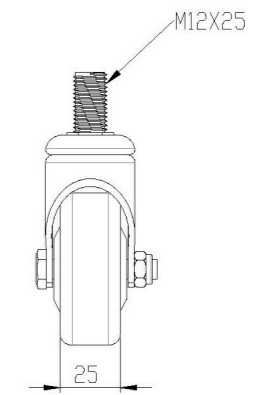

Unit: mm

Swivel Item No.	Brake Item No.	Rigid Item No.	Material	Dia. x Width	Height	Radius of gyration / brake	Load capacity (Kg)	Bearing Type
25PR12A	25PR12B	-	TPR SS41	63(2.5") X 25	88	57 / 90	70	608Z X 2
3PRM12A	3PRM12B	-		75(3") X 25	105	63 / 90		

Light duty 362 series

Application: trolleys for electronics factories, automation equipment, precision instruments and equipment, food machinery and equipment, medical equipment trolleys

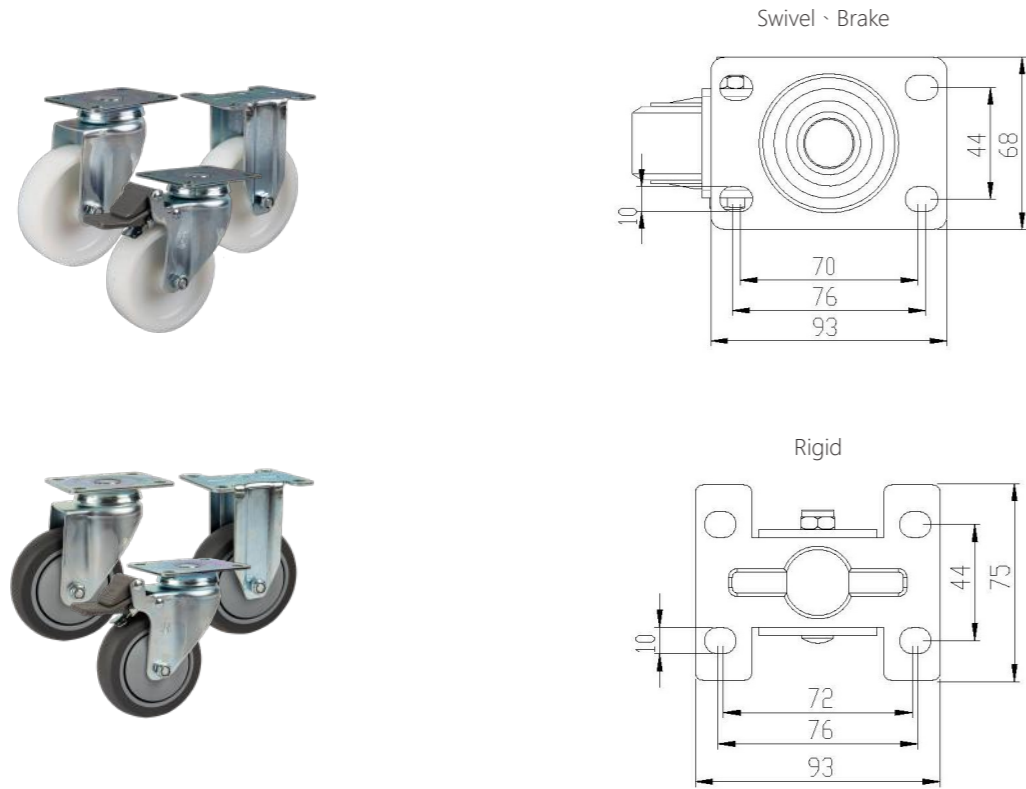

Unit: mm

Swivel Item No.	Brake Item No.	Rigid Item No.	Material	Dia. x Width	Height	Radius of gyration / brake	Load capacity (Kg)	Bearing Type
3NY362A	3NY362B	3NY362C	Nylon (White) SS41	75(3") X 32	111	77.5 / 107	100	608Z X 2
3NY362TA	3NY362TB	3NY362TC	Nylon (White) Bright Chrome					
3PR362A	3PR362B	3PR362C	TPR SS41					
3PR362TA	3PR362TB	3PR362TC	TPR Bright Chrome					

Light duty 362 series

Application: trolleys for electronics factories, automation equipment, precision instruments and equipment, food machinery and equipment, medical equipment trolleys

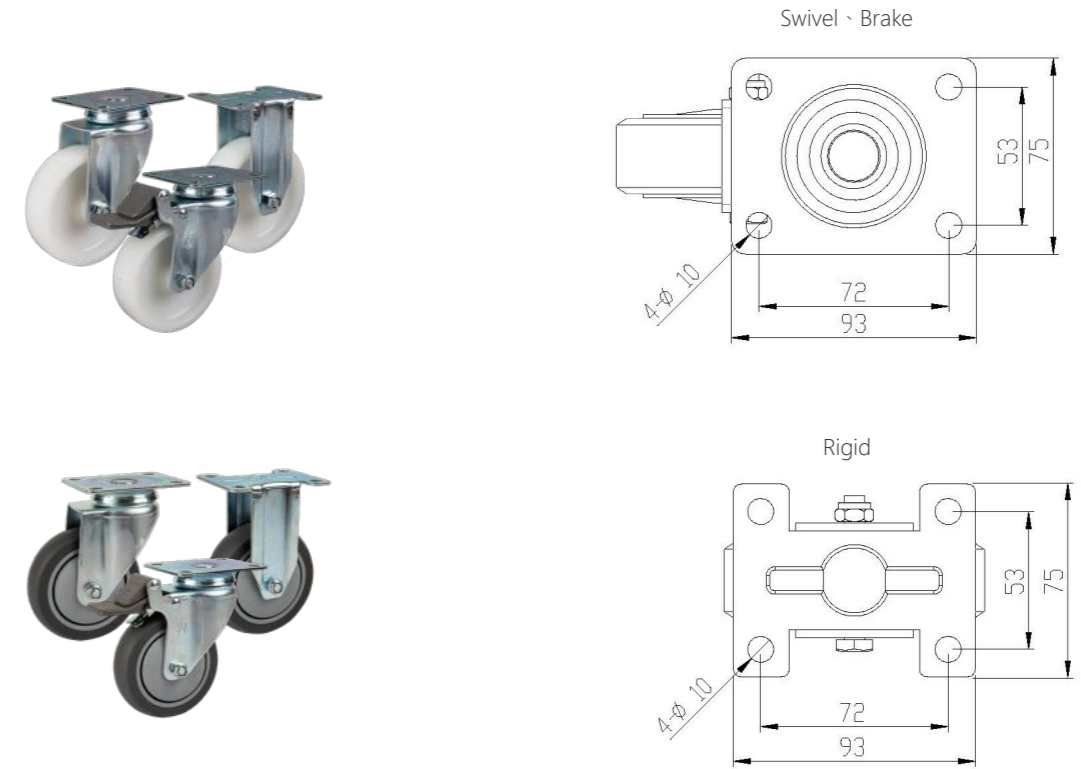

Unit: mm

Swivel Item No.	Brake Item No.	Rigid Item No.	Material	Dia. x Width	Height	Radius of gyration / brake	Load capacity (Kg)	Bearing Type	
4NY362A	4NY362B	4NY362C	Nylon (White) SS41	100(4") X 32	137	90 / 107	100	-	
5NY362A	5NY362B	5NY362C		125(5") X 32	163	103 / 112			
4NY362TA	4NY362TB	4NY362TC	Nylon (White) Bright Chrome	100(4") X 32	137	90 / 107			
5NY362TA	5NY362TB	5NY362TC		125(5") X 32	163	103 / 112			
4PR362A	4PR362B	4PR362C	TPR SS41	100(4") X 32	137	90 / 107			608Z X 2
5PR362A	5PR362B	5PR362C		125(5") X 32	163	103 / 112			6202 X 1
4PR362TA	4PR362TB	4PR362TC	TPR Bright Chrome	100(4") X 32	137	90 / 107	608Z X 2		
5PR362TA	5PR362TB	5PR362TC		125(5") X 32	163	103 / 112	6202 X 1		

Light duty 362 series

Application: trolleys for electronics factories, automation equipment, precision instruments and equipment, food machinery and equipment, medical equipment trolleys

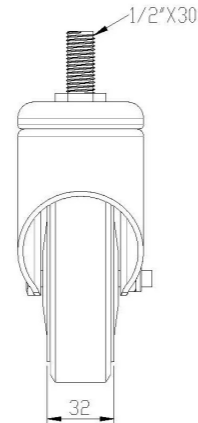

Unit: mm

Swivel Item No.	Brake Item No.	Rigid Item No.	Material	Dia. x Width	Height	Radius of gyration / brake	Load capacity (Kg)	Bearing Type
3NY3624A	3NY3624B	-	Nylon (White) SS41	75(3") X 32	114	77.5 / 107	100	608Z X 2
4NY3624A	4NY3624B	-		100(4") X 32	141	90 / 107		
5NY3624A	5NY3624B	-		125(5") X 32	167	103 / 107		
3NY362T4A	3NY362T4B	-	Nylon (White) Bright Chrome	75(3") X 32	114	77.5 / 107		
4NY362T4A	4NY362T4B	-		100(4") X 32	141	90 / 107		
5NY362T4A	5NY362T4B	-		125(5") X 32	167	103 / 107		
3PR3624A	3PR3624B	-	TPR SS41	75(3") X 32	114	77.5 / 107		
4PR3624A	4PR3624B	-		100(4") X 32	141	90 / 107		
5PR3624A	5PR3624B	-		125(5") X 32	167	103 / 107		
3PR362T4A	3PR362T4B	-	TPR Bright Chrome	75(3") X 32	114	77.5 / 107		
4PR362T4A	4PR362T4B	-		100(4") X 32	141	90 / 107		
5PR362T4A	5PR362T4B	-		125(5") X 32	167	103 / 107		

Electrically conductive caster series

Application: Various types of semiconductor equipment and trolleys for clean rooms, automation equipment, precision instruments and equipment, carts

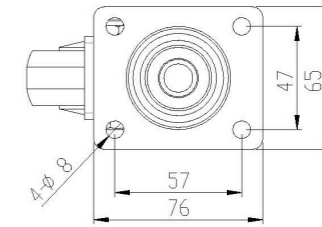

Unit: mm

Electrical Conductivity (EC) : $10^3 \sim 10^5 \Omega$

Swivel Item No.	Brake Item No.	Rigid Item No.	Material	Dia. x Width	Height	Radius of gyration / brake	Load capacity (Kg)	Bearing Type
3ELMTA	3ELMTB	-	Conductive rubber Bright Chrome	75(3") X 25	104	68 / 100	60	608Z X 2

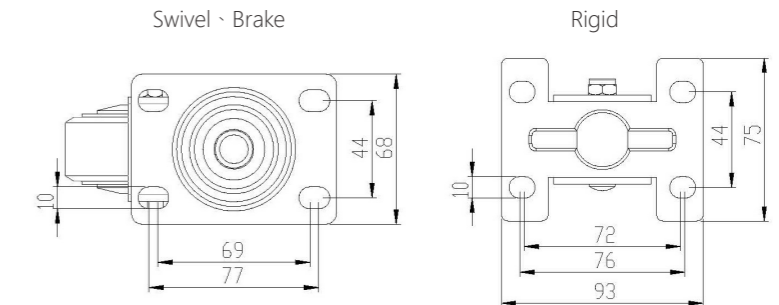

Unit: mm

Electrical Conductivity (EC) : $10^3 \sim 10^5 \Omega$

Swivel Item No.	Brake Item No.	Rigid Item No.	Material	Dia. x Width	Height	Radius of gyration / brake	Load capacity (Kg)	Bearing Type
3EL362TA	3EL362TB	3EL362TC	Conductive rubber Bright Chrome	75(3") X 32	110	76.5 / 107	60	608Z X 2

Electrically conductive caster series

Application: Various types of semiconductor equipment and trolleys for clean rooms, automation equipment, precision instruments and equipment, carts

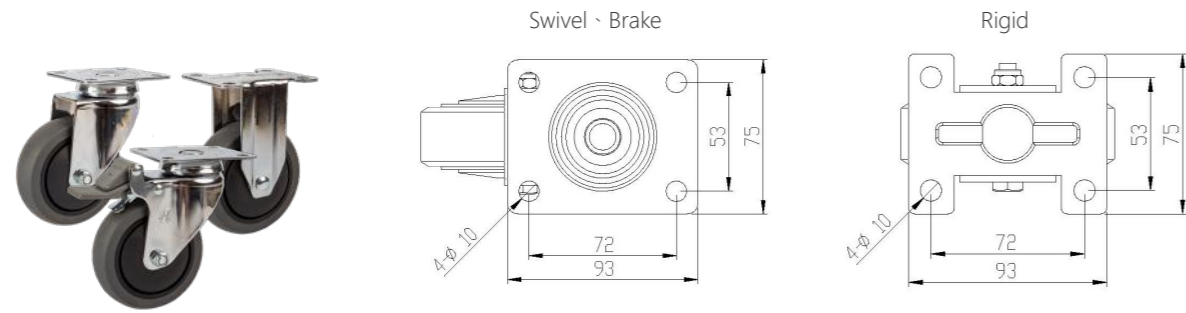

Unit: mm

Electrical Conductivity (EC) : $10^3 \sim 10^5 \Omega$

Swivel Item No.	Brake Item No.	Rigid Item No.	Material	Dia. x Width	Height	Radius of gyration / brake	Load capacity (Kg)	Bearing Type
4EL362TA	4EL362TB	4EL362TC	Conductive rubber Bright Chrome	100(4") X 32	138	89 / 107	80	608Z X 2
5EL362TA	5EL362TB	5EL362TC		125(5") X 32	163	102 / 107		6202 X 1

Electrically conductive caster series

Application: Various types of semiconductor equipment and trolleys for clean rooms, automation equipment, precision instruments and equipment, carts

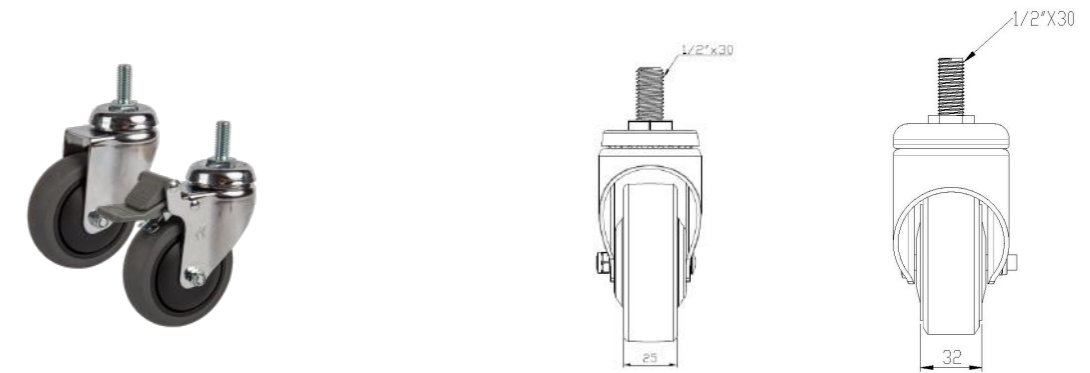

Unit: mm

Electrical Conductivity (EC) : $10^3 \sim 10^5 \Omega$

Swivel Item No.	Brake Item No.	Rigid Item No.	Material	Dia. x Width	Height	Radius of gyration / brake	Load capacity (Kg)	Bearing Type
3ELMT4A	3ELMT4B	-	Conductive rubber Bright Chrome	75(3") X 25	105	68 / 90	60	608Z X 2
3EL362T4A	3EL362T4B	-		75(3") X 32	113.5	77.5 / 107	80	
4EL362T4A	4EL362T4B	-		100(4") X 32	138	90 / 107		



Unit: mm

Electrical Conductivity (EC) : $10^3 \sim 10^5 \Omega$

Swivel Item No.	Brake Item No.	Rigid Item No.	Material	Dia. x Width	Height	Radius of gyration / brake	Load capacity (Kg)	Bearing Type
5EL362T5A	5EL362T5B	-	Conductive rubber Bright Chrome	125(5") X 32	165	102.5 / 112	80	6202 X 1

Stainless steel electrically conductive caster series

Application: Biochemical technology workshops, electronic equipment trolleys, medical equipment, cold chain logistic, fisheries, central kitchens, food machinery

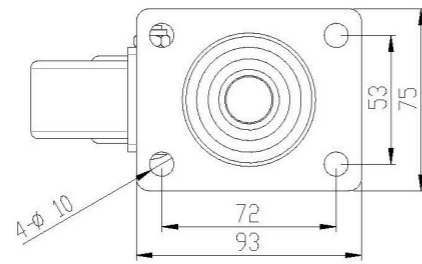

Unit: mm

Electrical Conductivity (EC) : $10^3 \sim 10^5 \Omega$

Swivel Item No.	Brake Item No.	Rigid Item No.	Material	Dia. x Width	Height	Radius of gyration / brake	Load capacity (Kg)	Bearing Type
3ELSTA	3ELSTB	3ELSTC	Conductive rubber SUS304	75(3") X 32	110	77.5 / 106	80	608Z X 2
4ELSTA	4ELSTB	4ELSTC		100(4") X 32	138	90 / 106		6202 X 1
5ELSTA	5ELSTB	5ELSTC		125(5") X 32	163	102.5 / 106		

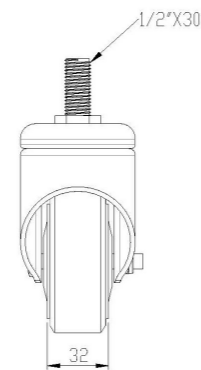

Unit: mm

Electrical Conductivity (EC) : $10^3 \sim 10^5 \Omega$

Swivel Item No.	Brake Item No.	Rigid Item No.	Material	Dia. x Width	Height	Radius of gyration / brake	Load capacity (Kg)	Bearing Type
3ELST4A	3ELST4B	-	Conductive rubber SUS304	75(3") X 32	112.5	77.5 / 106	80	608Z X 2
4ELST4A	4ELST4B	-		100(4") X 32	140	90 / 106		6202 X 1
5ELST4A	5ELST4B	-		125(5") X 32	165.5	102.5 / 106		

Anti static caster series

Application: Various types of semiconductor equipment and trolleys for clean rooms, automation equipment, precision instruments and equipment, carts

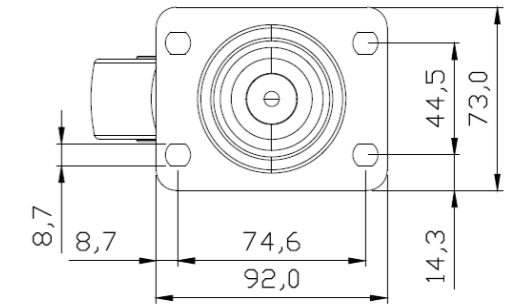

Unit: mm

Anti static : $10^6 \sim 10^9 \Omega$

Swivel Item No.	Brake Item No.	Rigid Item No.	Material	Dia. x Width	Height	Radius of gyration / brake	Load capacity (Kg)	Bearing Type
3ATBHDA	3ATBHDB	3ATBHDC	Anti static ED Coating (Black)	75(3") X 32	111.5	71.5 / 144.7	100	6002RS X 2
4ATBHDA	4ATBHDB	4ATBHDC		100(4") X 32	137.5	84 / 157.2	120	6202RS X 2
5ATBHDA	5ATBHDB	5ATBHDC		125(5") X 32	164.5	96.5 / 169.7	150	

Light duty stainless steel caster series

Application: Biochemical technology workshops, electronic equipment trolleys, medical equipment, cold chain logistic, fisheries, central kitchens, food machinery

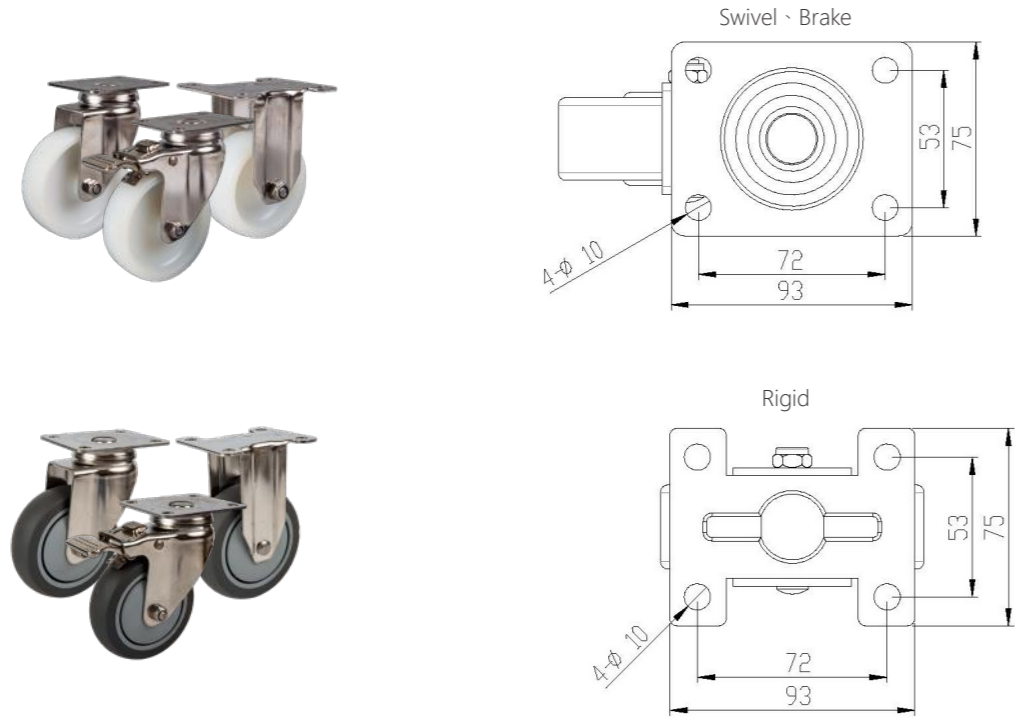

Unit: mm

Swivel Item No.	Brake Item No.	Rigid Item No.	Material	Dia. x Width	Height	Radius of gyration / brake	Load capacity (Kg)	Bearing Type	
3NYSTA	3NYSTB	3NYSTC	Nylon (White) SUS304	75(3") X 32	110	77.5 / 106	120	-	
4NYSTA	4NYSTB	4NYSTC		100(4") X 32	138	90 / 108			
5NYSTA	5NYSTB	5NYSTC		125(5") X 32	163	102.5 / 113			
3PRSTA	3PRSTB	3PRSTC	TPR SUS304	75(3") X 32	110	77.5 / 106			6202 X 1
4PRSTA	4PRSTB	4PRSTC		100(4") X 32	138	90 / 108			
5PRSTA	5PRSTB	5PRSTC		125(5") X 32	163	102.5 / 113			

Light duty stainless steel caster series

Application: Biochemical technology workshops, electronic equipment trolleys, medical equipment, cold chain logistic, fisheries, central kitchens, food machinery

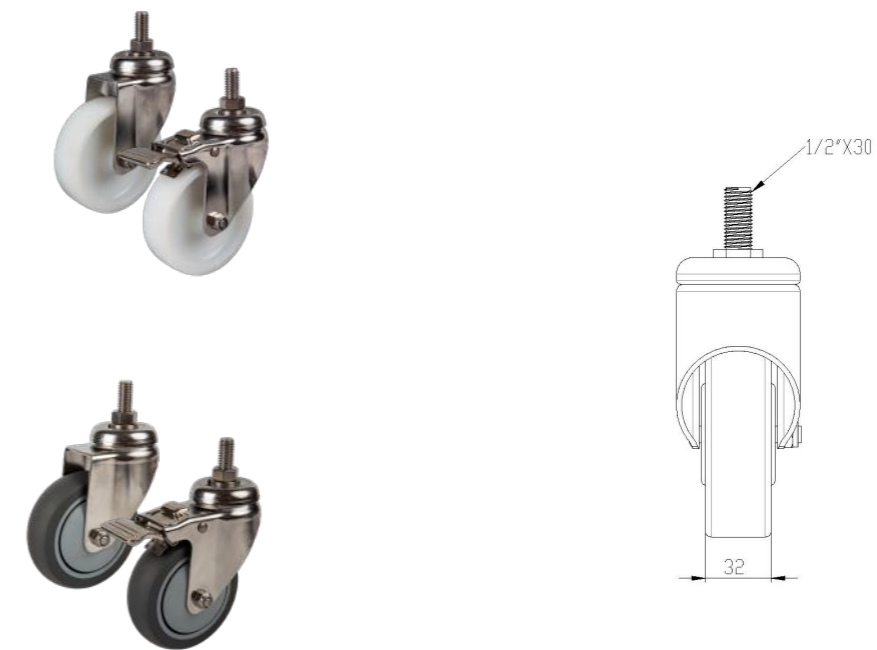

Unit: mm

Swivel Item No.	Brake Item No.	Rigid Item No.	Material	Dia. x Width	Height	Radius of gyration / brake	Load capacity (Kg)	Bearing Type	
3NYST4A	3NYST4B	-	Nylon (White) SUS304	75(3") X 32	113	77.5 / 106	120	-	
4NYST4A	4NYST4B	-		100(4") X 32	141	90 / 108			
5NYST4A	5NYST4B	-		125(5") X 32	166	102.5 / 113			
3PRST4A	3PRST4B	-	TPR SUS304	75(3") X 32	113	77.5 / 106			6202 X 1
4PRST4A	4PRST4B	-		100(4") X 32	141	90 / 108			
5PRST4A	5PRST4B	-		125(5") X 32	166	102.5 / 113			

Medium-heavy duty stainless steel caster series

Application: Biochemical technology workshops, electronic equipment trolleys, medical equipment, cold chain logistic, fisheries, central kitchens, food machinery

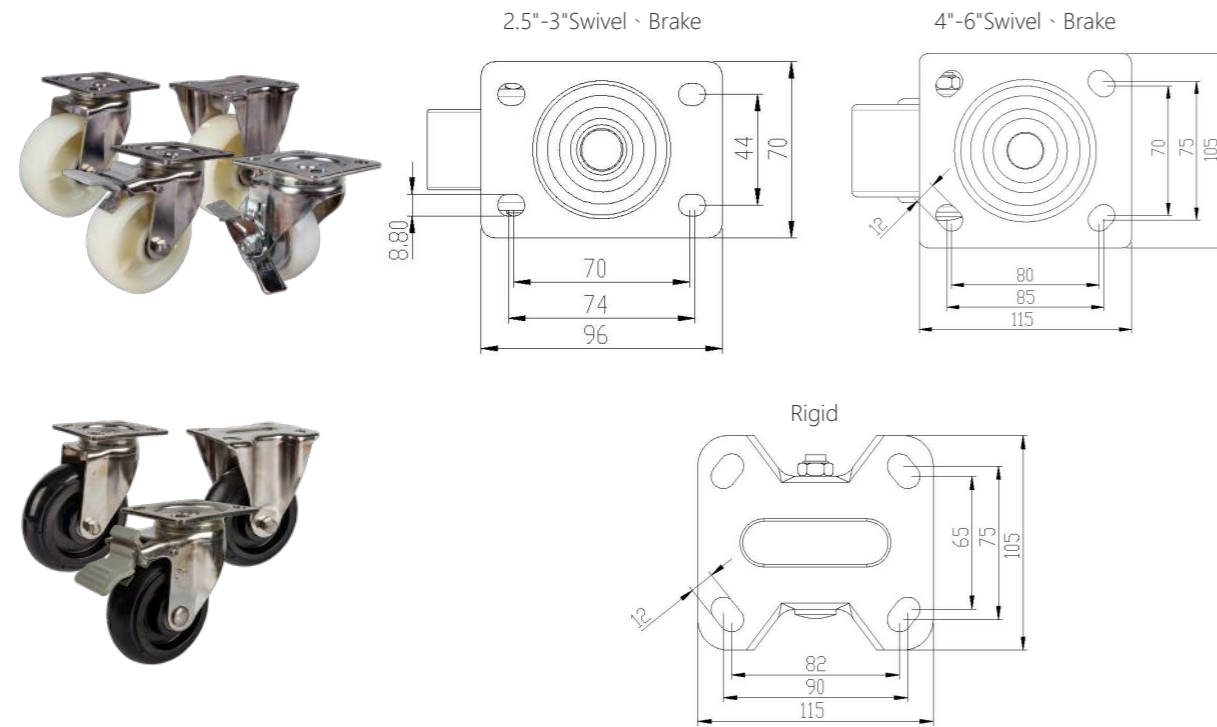

Unit: mm

Swivel Item No.	Brake Item No.	Rigid Item No.	Material	Dia. x Width	Height	Radius of gyration / brake	Load capacity (Kg)	Bearing Type
25NYSTHOA	25NYSTHOB (Side brake)	-	Nylon (White) SUS304	65(2.5") X 32	90	59.5 / 59.5	150	6202 X 2
3NYSTHOA	3NYSTHOB	-		75(3") X 32	109	69.5 / 102	200	
4NYSTHOA	4NYSTHOB	4NYSTHOC	Nylon (White) SUS304	100(4") X 50	141	94 / 132	300	
5NYSTHOA	5NYSTHOB	5NYSTHOC		125(5") X 50	167	107 / 132		
6NYSTHOA	6NYSTHOB	6NYSTHOC		150(6") X 50	191	119 / 132		
4ERSTHOA	4ERSTHOB	4ERSTHOC	Rubber SUS304	100(4") X 50	141	94 / 132	200	
5ERSTHOA	5ERSTHOB	5ERSTHOC		125(5") X 50	167	107 / 132		
6ERSTHOA	6ERSTHOB	6ERSTHOC		150(6") X 50	191	119 / 132		

High-temp. resistance nylon caster C2 series

Application: Oven, Food Machinery

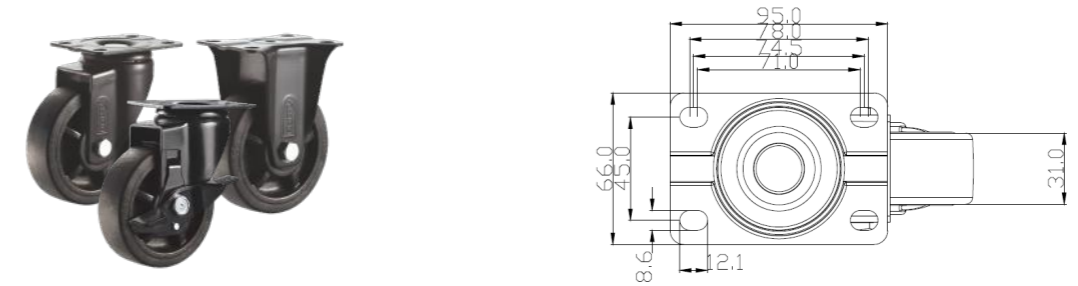

Unit: mm

Swivel Item No.	Brake Item No.	Rigid Item No.	Material	Dia. x Width	Height	Radius of gyration / brake	Load capacity (Kg)	Bearing Type
3RLC2A	3RLC2KB	3RLC2C	High-temp. resistance black nylon (260° C / 500° F) ED Coating (Black)	75(3") X 32	106	72.5	100	6001 X 2
4RLC2A	4RLC2KB	4RLC2C		100(4") X 32	131	85	115	
5RLC2A	5RLC2KB	5RLC2C		125(5") X 32	157	100.5	150	

Medium duty leveling caster series

Application: Medium duty machine, Heavy duty equipment, Automatic equipment, Test equipment.

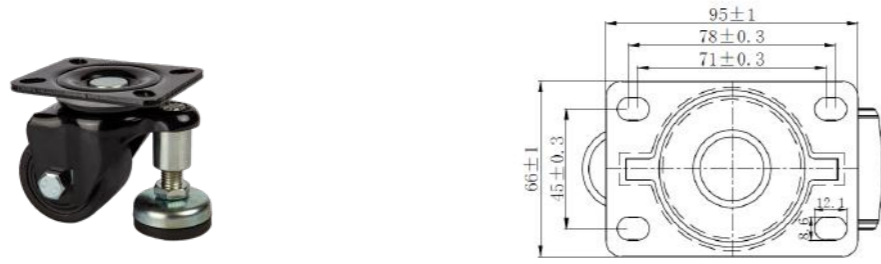

Unit: mm Screw adjustment height ± 8 mm ~ ± 10 mm

Swivel Item No.	Brake Item No.	Rigid Item No.	Material	Dia. x Width	Height	Radius of gyration / brake	Load capacity (Kg)	Bearing Type
25A1APS	-	-	Nylon (Black)	63(2.5") X 45	85	57	200	6202 X 2
3A1APS	-	-	ED Coating (Black)	75(3") X 45	98	64	250	

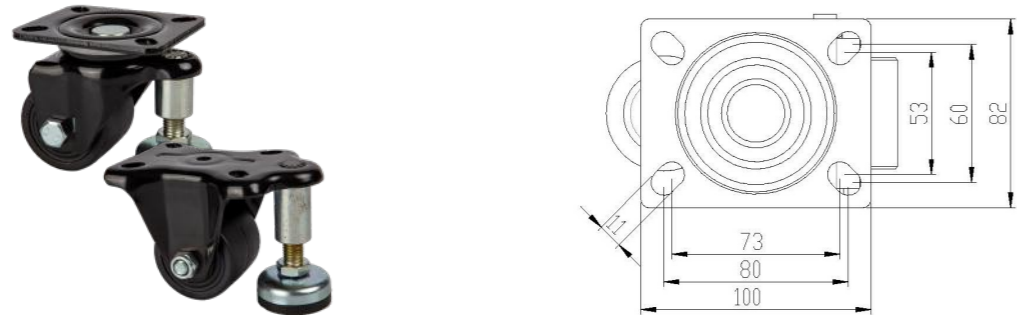

Unit: mm Screw adjustment height ± 8 mm ~ ± 10 mm

Swivel Item No.	Brake Item No.	Rigid Item No.	Material	Dia. x Width	Height	Radius of gyration / brake	Load capacity (Kg)	Bearing Type
25A2APS	-	25A2CPS	Nylon (Black)	63(2.5") X 50	96	58	400	6202 X 2
3A2APS	-	3A2CPS	ED Coating (Black)	75(3") X 50	108	68	500	

Leveling caster GDN/GD series

FOOT MASTER®
Casters & Wheels



The leveling caster is a two-in-one or three-in-one combination that combines a horizontally adjustable foot base with a caster to save unnecessary operating time and improve the user's work efficiency.



▶ A black powder coating caster frame is available.

Unit: mm Temperature : -10~+90°C

Swivel Item No.	Wheel material	Surface Treatment	Dia.	Width	Height	Plate size	Plate hole distance	Plate aperture	Plate center bolt	Leveling Extent	Load capacity (Kg)
GDN-40-F-NYN	Nylon66	Powder Coating SS41	42	20	71	55 X 55	42 X 42	6.5	-	10	50
GDN-60-F-NYN			50	25	82	73 X 73	58 X 58	7	-	10	250
GDN-80-F-NYN			63	28	103	90 X 90	70 X 70	9	-	15	500
GDN-100-F-NYN			75	30	120	95 X 95	70 X 70	11	-	12	750
GD-120-F-NYN			75	30	120	95 X 95	70 X 70	11	-	12	1000
GD-150-F-MCN	MC Nylon		90	55	132	100 X 100	70 X 70	13	-	15	1500
GDN-40-S-NYN	Nylon66		42	20	71	-	-	-	M8 X P1.25	10	50
GDN-60-S-NYN			50	25	82	-	-	-	M12 X P1.75	10	250
GDN-80-S-NYN			63	28	103	-	-	-	M12 X P1.75	15	500
GDN-100-S-NYN			75	30	120	-	-	-	M16 X P2.0	12	750
GD-120-S-NYN		75	30	120	-	-	-	M16 X P2.0	12	1000	

FOOT MASTER® leveling casters allow for mobility and secure installation. Rubber base for casters. It can absorb minor vibrations and perfectly maintain the fixed state of the device. When installing and moving equipment, the casters and leveling feet need to be used separately, and the leveling casters will combine the above two functions. When the positioning of the equipment needs to be changed, the adjustable rubber base can be moved perfectly for multi-purpose using of Caster function.



Leveling caster GDR series

The leveling caster is a two-in-one or three-in-one combination that combines a horizontally adjustable foot base with a caster to save unnecessary operating time and improve the user's work efficiency.



▀ A black powder coating caster frame is available.

Unit: mm Temperature : -10~+90°C

Swivel Item No.	Wheel material	Surface Treatment	Dia.	Width	Height	Plate size	Plate hole distance	Plate aperture	Plate center bolt	Leveling Extent	Load capacity (Kg)
GDR-60-F-NYN	Nylon66	Powder Coating SS41	50	25	82	73 X 73	58 X 58	7	-	10	250
GDR-80-F-NYN			63	28	103	90 X 90	70 X 70	9	-	15	500
GDR-60-S-NYN			50	25	82	-	-	-	M12 X P1.75	10	250
GDR-80-S-NYN			63	28	103	-	-	-	M12 X P1.75	15	500

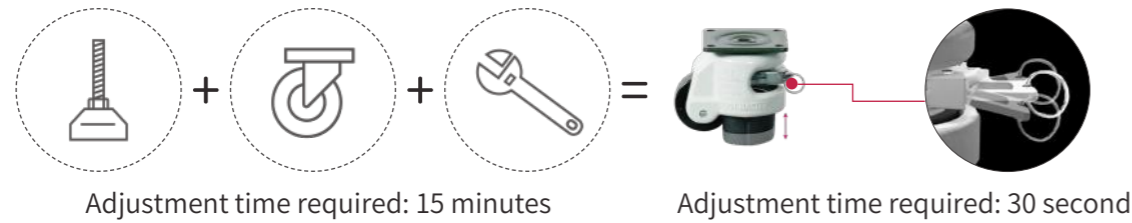

Stainless leveling caster SGDN series

The leveling caster is a two-in-one or three-in-one combination that combines a horizontally adjustable foot base with a caster to save unnecessary operating time and improve the user's work efficiency.



Unit: mm Temperature : -10~+90°C

Swivel Item No.	Wheel material	Surface Treatment	Dia.	Width	Height	Plate size	Plate hole distance	Plate aperture	Plate center bolt	Leveling Extent	Load capacity (Kg)
SGDN-60-F-NYN	Nylon66	Stainless	50	25	82	73 X 73	58 X 58	7	-	10	280
SGDN-80-F-NYN			63	28	103	90 X 90	70 X 70	9	-	15	550
SGDN-60-S-NYN			50	25	82	-	-	-	M12 X P1.75	10	280
SGDN-80-S-NYN			63	28	103	-	-	-	M12 X P1.75	15	550

FOOT MASTER® leveling casters allow for mobility and secure installation. Rubber base for casters. It can absorb minor vibrations and perfectly maintain the fixed state of the device. When installing and moving equipment, the casters and leveling feet need to be used separately, and the leveling casters will combine the above two functions. When the positioning of the equipment needs to be changed, the adjustable rubber base can be moved perfectly for multi-purpose using of Caster function.

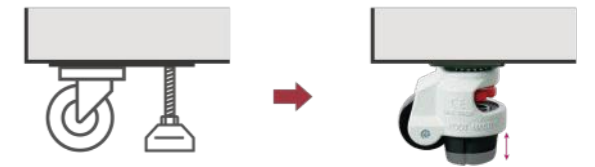

Shock absorbing caster GDS series

Using special rubber shock-absorbing casters that absorb tiny vibrations, vibration-sensitive products such as semiconductors and chips can be protected during movement. It can also prevent the casters from leaving the ground during towing, reducing friction noise and natural noise.



Enhance protection from noise and external impacts

Shock-absorbing caster

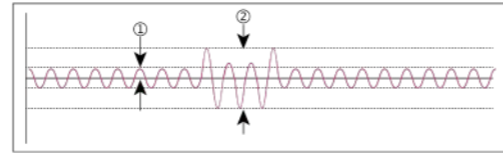
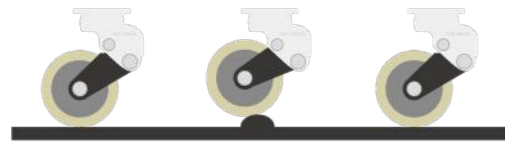

Industrial caster

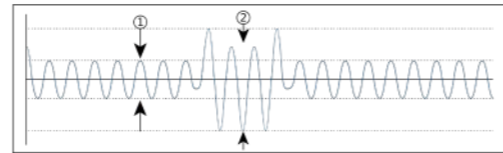

① Reduce noise

FOOT MASTER® shock-absorbing wheels use special rubber that absorbs shock. This special rubber eliminates vibrations transmitted from the metal during movement. Less noise than coil springs make the shock absorbing casters much better.

② Protection from external impact

Small vibrations caused by movement of products such as semiconductors and chips can cause fatal defects. As shown in the picture above, special rubber shock absorption using FOOT MASTER® technology will absorb impacts like a sponge, thereby greatly reducing external impacts caused by uneven floors and preventing product damage.

Unit: mm

Temperature : -10~+90°C

Swivel Item No.	Brake Item No.	Rigid Item No.	Rigid with Brake Item No.	Wheel material	Surface Treatment	Dia.	Width	Height	Eccentricity	Plate size	Plate hole distance	Plate aperture	Load capacity (Kg)
GDS-50-ASF-EUS	GDS-50-BSF-EUS	GDS-50-ARF-EUS	GDS-50-BRF-EUS	PU Shore A80	Aluminum Powder Coating	50	23	100-10	30~34	55 X 55	42 X 42	6.5	40
GDS-65-ASF-EUS	GDS-65-BSF-EUS	GDS-65-ARF-EUS	GDS-65-BRF-EUS			64		115-10	30~36				50
GDS-75-ASF-LUD	-	GDS-75-ARF-LUD	-	PU Shore A90		75	30	130-15	35~39	73 X 73	58 X 58	7	90
GDS-100-ASF-LUD	GDS-100-BSF-LUD	GDS-100-ARF-LUD	GDS-100-BRF-LUD			100		160-20	45~53				100
GDS-125-ASF-LUD	GDS-125-BSF-LUD	GDS-125-ARF-LUD	GDS-125-BRF-LUD			125		187-20	45~54				
GDS-130-ASF-HUD	GDS-130-BSF-HUD	GDS-130-ARF-HUD	GDS-130-BRF-HUD	PU Shore A95		130	40	200-30	36~50	95 X 95	70 X 70	11	350
GDS-150-ASF-HUD	GDS-150-BSF-HUD	GDS-150-ARF-HUD	GDS-150-BRF-HUD			150		230-30	36~50				
GDS-200-ASF-HUD	GDS-200-BSF-HUD	GDS-200-ARF-HUD	GDS-200-BRF-HUD			200		270-35	55~76				

Shock absorbing caster GDS series



▶ Bolt type selection

Mechanism wheel, wheel & caster, AMR/OHT, Caster, Leveling Feet, Aluminum accessories, Trolley

Shock absorbing caster GSST series

FOOT MASTER®
Casters & Wheels

Using special rubber shock-absorbing casters that absorb tiny vibrations, vibration-sensitive products such as semiconductors and chips can be protected during movement. It can also prevent the casters from leaving the ground during towing, reducing friction noise and natural noise.



Enhance protection from noise and external impacts

Shock-absorbing caster

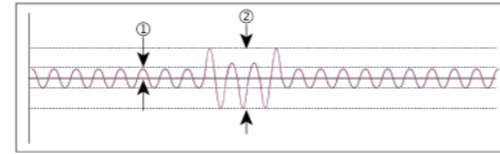
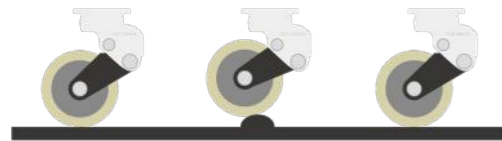

Industrial caster

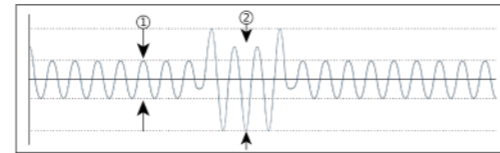

① Reduce noise

FOOT MASTER® shock-absorbing wheels use special rubber that absorbs shock. This special rubber eliminates vibrations transmitted from the metal during movement. Less noise than coil springs make the shock absorbing casters much better.

② Protection from external impact

Small vibrations caused by movement of products such as semiconductors and chips can cause fatal defects. As shown in the picture above, special rubber shock absorption using FOOT MASTER® technology will absorb impacts like a sponge, thereby greatly reducing external impacts caused by uneven floors and preventing product damage.

Unit: mm

Temperature : -10~+90°C

Swivel Item No.	Brake Item No.	Rigid Item No.	Wheel material	Surface Treatment	Dia.	Width	Height	Eccentricity	Plate size	Plate hole distance	Plate aperture	Load capacity (Kg)
GSST-130-ASF-HUD	GSST-130-BSF-HUD	GSST-130-ARF-HUD	PU Shore A95	Aluminum Powder Coating	130	40	200-21	46~55	160 X 120	130 X 75	15	400
GSST-150-ASF-HUD	GSST-150-BSF-HUD	GSST-150-ARF-HUD			150		232-30	46~61				
GSST-200-ASF-HUD	GSST-200-BSF-HUD	GSST-200-ARF-HUD			200		279-30	50~70				
GSST-200W-ASF-HUD	-	GSST-200W-ARF-HUD			200	48	279-30	50~68	160 X 135	123 X 93	14	500
GSST-250-ASF-HUD	-	GSST-250-ARF-HUD			250	60	362-30	78~92	175 X 140	140 X 105	14	1350



Extra-heavy duty caster -GHP series



Heavy duty caster series has a forged wheel frame with polyurethane or MC nylon. Polyurethane is softer than MC nylon, which can reduce ground noise and damage caused by heavy duty caster. MC nylon material is harder, has excellent turning and rotation properties when walking, and has a higher load capacity. Heavy duty caster pay great attention to safety and stability, so the quality of FOOT MASTER® heavy duty caster series is the first choice for heavy duty caster.

Application: aerospace industry, AGV/AMR, automobile production lines, power supplies, etc.

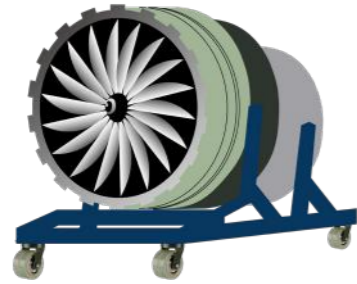

Aerospace industry

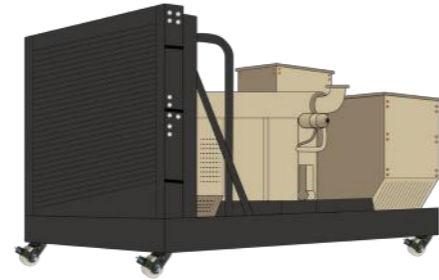

Power supplies

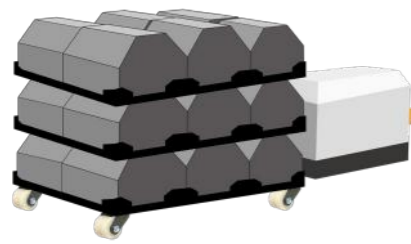

AGV/AMR, automobile production lines

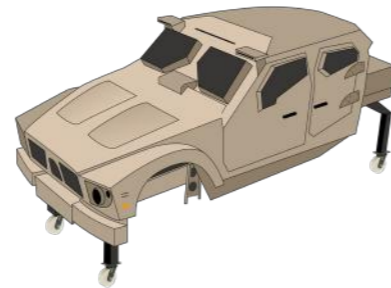

Automobile Factory

Unit: mm

Temperature : -10~+90°C

Swivel Item No.	Brake Item No.	Rigid Item No.	Wheel material	Surface Treatment	Dia.	Width	Height	Eccentricity	Plate size	Plate hole distance	Plate aperture	Load capacity (Kg)
GHP-150-ASF-MUD	GHP-150-BSF-MUD	GHP-150-ARF-MUD	PU Shore A95	Powder Coating	150	50	200	65	158 X 114	133 X 86 125 X 62	13	700
GHP-175-ASF-MUD	GHP-175-BSF-MUD	GHP-175-ARF-MUD			175		225	60				800
GHP-200-ASF-MUD	GHP-200-BSF-MUD	GHP-200-ARF-MUD			200		250	55				900

Extra-heavy duty caster -GHP series



Heavy duty caster GF series



Heavy duty caster series has a forged wheel frame with polyurethane or MC nylon. Polyurethane is softer than MC nylon, which can reduce ground noise and damage caused by heavy duty caster. MC nylon material is harder, has excellent turning and rotation properties when walking, and has a higher load capacity. Heavy duty caster pay great attention to safety and stability, so the quality of FOOT MASTER® heavy duty caster series is the first choice for heavy duty caster.

Application: aerospace industry, AGV/AMR, automobile production lines, power supplies, etc.

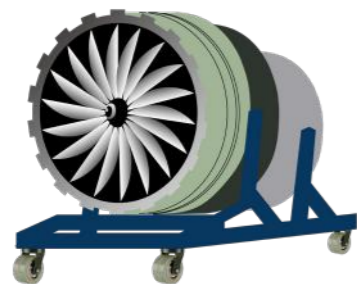

Aerospace industry

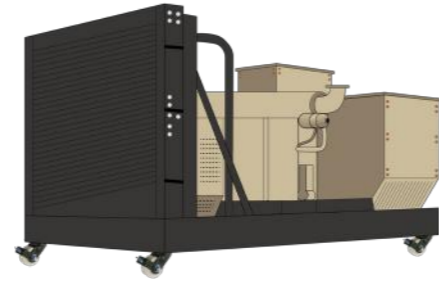

Power supplies

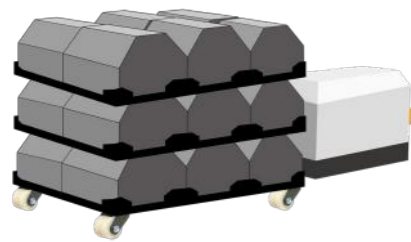

AGV/AMR, automobile production lines

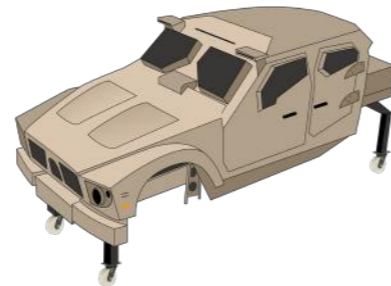

Automobile Factory

Unit: mm

Temperature : -10~+90°C

Swivel Item No.	Brake Item No.	Rigid Item No.	Rigid with Brake Item No.	Wheel material	Surface Treatment	Dia.	Width	Height	Eccentricity	Plate size	Plate hole distance	Plate aperture	Load capacity (Kg)			
GF-100-ASF-MUD-SIL	GF-100-BSF-MUD-SIL	GF-100-ARF-MUD-SIL	GF-100-BRF-MUD-SIL	PU Shore A95	Powder Coating	100	64	145	37	159 X 114	130 X 74	13	650			
GF-125-ASF-MUD-SIL	GF-125-BSF-MUD-SIL	GF-125-ARF-MUD-SIL	GF-125-BRF-MUD-SIL			125		167	44				750			
GF-150-ASF-MUD-SIL	GF-150-BSF-MUD-SIL	GF-150-ARF-MUD-SIL	GF-150-BRF-MUD-SIL			150		190	52				800			
GF-200-ASF-MUD-SIL	GF-200-BSF-MUD-SIL	GF-200-ARF-MUD-SIL	GF-200-BRF-MUD-SIL			200		257	57				850			
GF-250-ASF-MUD-SIL	GF-250-BSF-MUD-SIL	GF-250-ARF-MUD-SIL	GF-250-BRF-MUD-SIL			250		300	61				1200			
GF-100-ASF-MCD-SIL	GF-100-BSF-MCD-SIL	GF-100-ARF-MCD-SIL	GF-100-BRF-MCD-SIL	MC Nylon Shore D80		100	64	145	37				159 X 114	130 X 74	13	800
GF-125-ASF-MCD-SIL	GF-125-BSF-MCD-SIL	GF-125-ARF-MCD-SIL	GF-125-BRF-MCD-SIL			125		167	44							900
GF-150-ASF-MCD-SIL	GF-150-BSF-MCD-SIL	GF-150-ARF-MCD-SIL	GF-150-BRF-MCD-SIL			150		190	52							1000
GF-200-ASF-MCD-SIL	GF-200-BSF-MCD-SIL	GF-200-ARF-MCD-SIL	GF-200-BRF-MCD-SIL			200		257	57							1100
GF-250-ASF-MCD-SIL	GF-250-BSF-MCD-SIL	GF-250-ARF-MCD-SIL	GF-250-BRF-MCD-SIL			250		300	61							1300

Heavy duty caster GF series



Heavy duty caster GXT series



Heavy duty caster series has a forged wheel frame with polyurethane or MC nylon. Polyurethane is softer than MC nylon, which can reduce ground noise and damage caused by heavy duty caster. MC nylon material is harder, has excellent turning and rotation properties when walking, and has a higher load capacity. Heavy duty caster pay great attention to safety and stability, so the quality of FOOT MASTER® heavy duty caster series is the first choice for heavy duty caster.

Application: aerospace industry, AGV/AMR, automobile production lines, power supplies, etc.

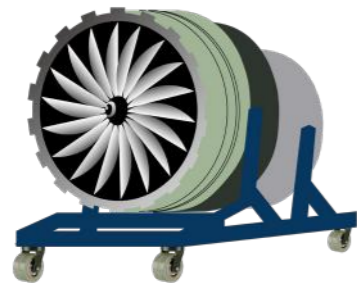

Aerospace industry

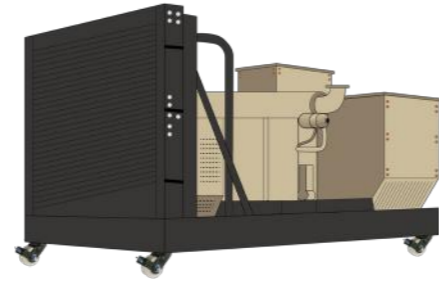

Power supplies

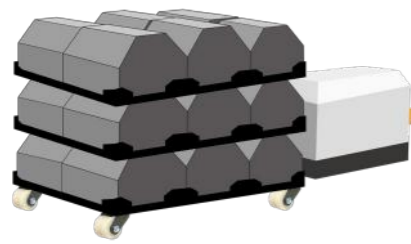

AGV/AMR, automobile production lines

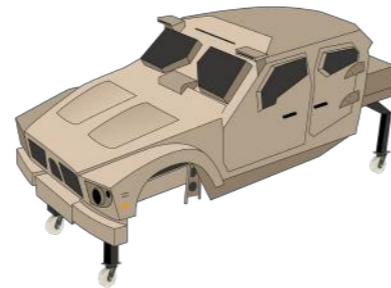

Automobile Factory

Unit: mm

Swivel Item No.	Brake Item No.	Rigid Item No.	Wheel material	Surface Treatment	Dia.	Width	Height	Eccentricity	Plate size	Plate hole distance	Plate aperture	Load capacity (Kg)			
GXT-80-ASF-HUD	GXT-80-BSF-HUD	GXT-80-ARF-HUD	PU Shore D70	Powder Coating SS41	80	48	120	40	100 X 85	80 X 60	9	500			
GXT-100-ASF-HUD	GXT-100-BSF-HUD	GXT-100-ARF-HUD			100		140					600			
GXT-125-ASF-HUD	GXT-125-BSF-HUD	GXT-125-ARF-HUD			125	70	170	77.5				175 X 140	140 X 105	14	1100
GXT-150-ASF-HUD	GXT-150-BSF-HUD	GXT-150-ARF-HUD			150		224	48							1500
GXT-200-ASF-HUD	GXT-200-BSF-HUD	GXT-200-ARF-HUD			200		275	60							2000
GXT-250-ASF-HUD	GXT-250-BSF-HUD	GXT-250-ARF-HUD			250		310	75							2300
GXT-80-ASF-MCD	GXT-80-BSF-MCD	GXT-80-ARF-MCD	MC Nylon Shore D80		80	48	120	40	100 X 85	80 X 60	9	800			
GXT-100-ASF-MCD	GXT-100-BSF-MCD	GXT-100-ARF-MCD			100		140					900			
GXT-125-ASF-MCD	GXT-125-BSF-MCD	GXT-125-ARF-MCD			125	70	170	77.5				175 X 140	140 X 105	14	1500
GXT-150-ASF-MCD	GXT-150-BSF-MCD	GXT-150-ARF-MCD			150		200	80							2200
GXT-200-ASF-MCD	GXT-200-BSF-MCD	GXT-200-ARF-MCD			200		260	75							2500
GXT-250-ASF-MCD	GXT-250-BSF-MCD	GXT-250-ARF-MCD			250		310								2700
GXT-100-ASF-NYD	GXT-100-BSF-NYD	GXT-100-ARF-NYD	Nylon66 Shore D70	100	48	140	40	100 X 85	80 X 60	9	900				

Temperature : -10~+90°C

Heavy duty caster GXT series



▸ Bolt type selection

Heavy duty caster GXTT series



Heavy duty caster series has a forged wheel frame with polyurethane or MC nylon. Polyurethane is softer than MC nylon, which can reduce ground noise and damage caused by heavy duty caster. MC nylon material is harder, has excellent turning and rotation properties when walking, and has a higher load capacity. Heavy duty caster pay great attention to safety and stability, so the quality of FOOT MASTER® heavy duty caster series is the first choice for heavy duty caster.

Application: aerospace industry, AGV/AMR, automobile production lines, power supplies, etc.

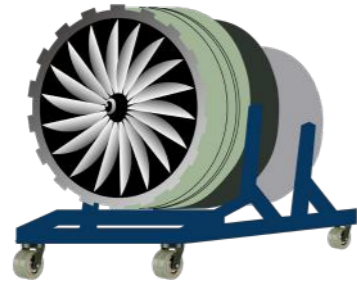

Aerospace industry

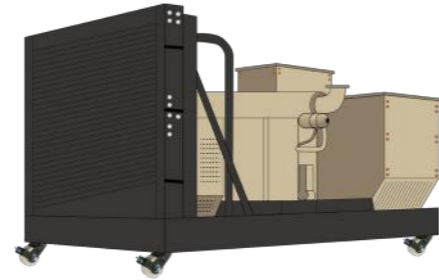

Power supplies

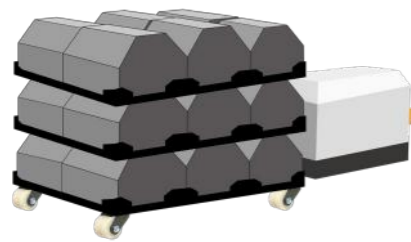

AGV/AMR, automobile production lines

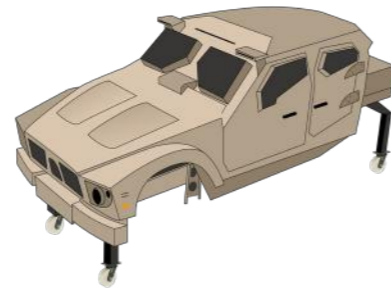

Automobile Factory

Unit: mm

Temperature : -10~+90°C

Swivel Item No.	Brake Item No.	Rigid Item No.	Rigid with Brake Item No.	Wheel material	Surface Treatment	Dia.	Width	Height	Eccentricity	Plate size	Plate hole distance	Plate aperture	Load capacity (Kg)
GXTT-75-ASF-HUD	GXTT-75-BSF-HUD	GXTT-75-ARF-HUD	GXTT-75-BRF-HUD	PU Shore D70	Powder Coating SS41	75	40 X 2	125	45	[SF] 140 X 110 [RF] 140 X 117	105 X 80	13	800
GXTT-100-ASF-HUD	GXTT-100-BSF-HUD	GXTT-100-ARF-HUD	GXTT-100-BRF-HUD			100		150	50				1100
GXTT-125-ASF-HUD	GXTT-125-BSF-HUD	GXTT-125-ARF-HUD	GXTT-125-BRF-HUD			125		175	55				1400
GXTT-75-ASF-MCD	GXTT-75-BSF-MCD	GXTT-75-ARF-MCD	GXTT-75-BRF-MCD	MC Nylon Shore D80		75		125	45				1700
GXTT-100-ASF-MCD	GXTT-100-BSF-MCD	GXTT-100-ARF-MCD	GXTT-100-BRF-MCD			100		150	50				2000
GXTT-125-ASF-MCD	GXTT-125-BSF-MCD	GXTT-125-ARF-MCD	GXTT-125-BRF-MCD			125		175	55				2300

Heavy duty caster GXTT series



Heavy duty caster GXTD series



Heavy duty caster series has a forged wheel frame with polyurethane or MC nylon. Polyurethane is softer than MC nylon, which can reduce ground noise and damage caused by heavy duty caster. MC nylon material is harder, has excellent turning and rotation properties when walking, and has a higher load capacity. Heavy duty caster pay great attention to safety and stability, so the quality of FOOT MASTER® heavy duty caster series is the first choice for heavy duty caster.

Application: aerospace industry, AGV/AMR, automobile production lines, power supplies, etc.

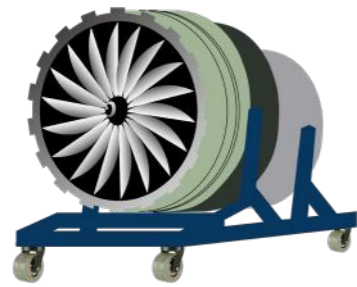

Aerospace industry

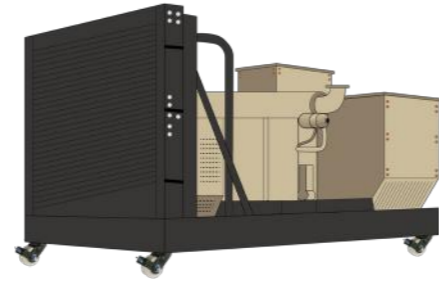

Power supplies

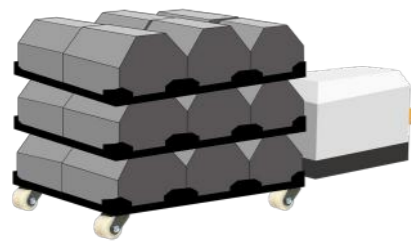

AGV/AMR, automobile production lines

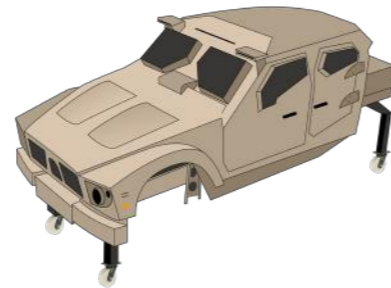

Automobile Factory

Unit: mm

Temperature : -10~+90°C

Swivel Item No.	Rigid Item No.	Wheel material	Surface Treatment	Dia.	Width	Height	Eccentricity	Plate size	Plate hole distance	Plate aperture	Load capacity (Kg)
GXTD-100-ASF-HUD	GXTD-100-ARF-HUD	PU Shore A95	Powder Coating SS41	100	29 X 2	156	35	140 X 112	103 X 78	11	400
GXTD-150-ASF-HUD	GXTD-150-ARF-HUD			150	40 X 2	200	35	145 X 130	115 X 100	11	800
GXTD-200-ASF-HUD	GXTD-200-ARF-HUD			200	65 X 2	265	50	210 X 210	170 X 170	17	2500
GXTD-250-ASF-HUD	GXTD-250-ARF-HUD			250	78 X 2	330	70	255 X 215	210 X 160	18	4500
GXTD-300-ASF-HUD	GXTD-300-ARF-HUD			300		390	80				5200
GXTD-250-ASF-MCD	GXTD-250-ARF-MCD	MC Nylon Shore D80		250	78 X 2	330	70	255 X 215	210 X 160	18	7000
GXTD-300-ASF-MCD	GXTD-300-ARF-MCD			300		390	80				8000

Heavy duty caster GXTD series



Heavy duty caster UGXT series



Heavy duty caster series has a forged wheel frame with polyurethane or MC nylon. Polyurethane is softer than MC nylon, which can reduce ground noise and damage caused by heavy duty caster. MC nylon material is harder, has excellent turning and rotation properties when walking, and has a higher load capacity. Heavy duty caster pay great attention to safety and stability, so the quality of FOOT MASTER® heavy duty caster series is the first choice for heavy duty caster.

Application: aerospace industry, AGV/AMR, automobile production lines, power supplies, etc.

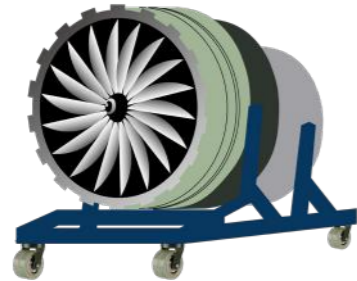

Aerospace industry

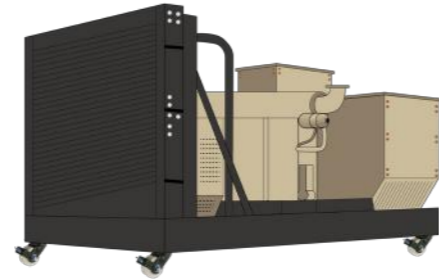

Power supplies

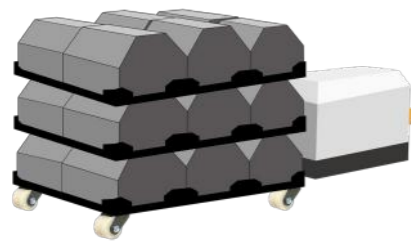

AGV/AMR, automobile production lines

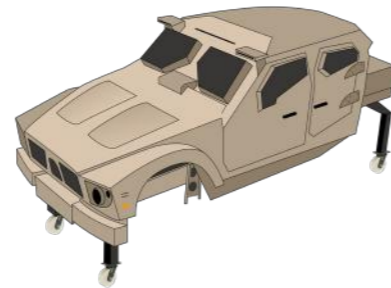

Automobile Factory

Unit: mm

Temperature: -10~+90°C

Swivel Item No.	Brake Item No.	Rigid Item No.	Wheel material	Surface Treatment	Dia.	Width	Height	Eccentricity	Plate size	Plate hole distance	Plate aperture	Load capacity (Kg)
UGXT-200-ASF-HUQ	UGXT-200-BSF-HUQ	UGXT-200-ARF-HUQ	PU Shore A95	Powder Coating SS41	200	100	280	75	255 X 215	210 X 160	18	2500
UGXT-250-ASF-HUQ	UGXT-250-BSF-HUQ	UGXT-250-ARF-HUQ			250		330	80				2900
UGXT-300-ASF-HUQ	UGXT-300-BSF-HUQ	UGXT-300-ARF-HUQ			300		380	90				3300
UGXT-200-ASF-MCQ	UGXT-200-BSF-MCQ	UGXT-200-ARF-MCQ	MC Nylon Shore D80		200		280	75				6000
UGXT-250-ASF-MCQ	UGXT-250-BSF-MCQ	UGXT-250-ARF-MCQ			250		330	80				7000
UGXT-300-ASF-MCQ	UGXT-300-BSF-MCQ	UGXT-300-ARF-MCQ			300		380	90				8000

Heavy duty caster UGXT series

